

# TM 9-6920-483-34-1

---

## TECHNICAL MANUAL

### DIRECT SUPPORT AND GENERAL SUPPORT MAINTENANCE MANUAL DRAGON TRAINING EQUIPMENT

---

This copy is a reprint which includes current pages from Changes 1 and 2.

HEADQUARTERS, DEPARTMENT OF THE ARMY

March 1977



Technical Manual )  
 )  
 No. 9-6920-483-34-1 )

HEADQUARTERS,  
 DEPARTMENT OF THE ARMY  
 Washington, D.C., 31 March 1977

DIRECT SUPPORT AND GENERAL SUPPORT MAINTENANCE MANUAL  
 DRAGON TRAINING EQUIPMENT

		Paragraph	Page
LIST OF ILLUSTRATIONS . . . . .			i i
PART NUMBER CONFIGURATION STATUS TABLE . . . . .			iv
SAFETY SUMMARY. . . . .			vi
CHAPTER 1. INTRODUCTION			
Section I. GENERAL			
Purpose and Scope . . . . .		1-1	1-1
Troubleshooting procedures. . . . .		1-2	1-1
Forms, Records, and Reports . . . . .		1-3	1-1
Security Responsibilities . . . . .		1-4	1-1
Report of Equipment Manual Improvements . . . . .		1-5	1-1
Shipment and Storage. . . . .		1-6	1-2
Section II. DESCRIPTION AND DATA			
Physical Description of Training. . . . .		1-7	1-2
Functional Description of the MTS . . . . .		1-8	1-2
Functional Description of the LET . . . . .		1-9	1-4
Functional Description of the IR Transmitter. . . . .		1-10	1-4
Section III. DEMOLITION TO PREVENT ENEMY USE			
Methods of Destruction. . . . .		1-11	1-4
Items to be Destroyed . . . . .		1-12	1-5
CHAPTER 2. THEORY OF OPERATION			
Operational Description of DRAGON Training Equipment. . . . .		2-1	2-1
Operational Description of the MTS. . . . .		2-2	2-2
Operational Description of the LET. . . . .		2-3	2-8
Operational Description of IR Transmitter . . . . .		2-4	2-8
Electrical and Electronic Functions of the MTS. . . . .		2-5	2-9

		Paragraph	Page
	Electrical and Electronic Functions of the MTS Battery Charger/Regulator . . . . .	2-6	2-4
	Electrical and Electronic Functions of the IR Transmitter. . . . .	2-7	2-64
	Mechanical Functions of the Trainer . . . . .	2-8	2-87
	Electronic Functions of the Trainer . . . . .	2-9	2-88
CHAPTER	3. TROUBLESHOOTING		
	General . . . . .	3-1	3-1
CHAPTER	4. CORRECTIVE MAINTENANCE		
	General . . . . .	4-1	4-1
	General Corrective Maintenance. . . . .	4-2	4-2
	Monitoring Set. . . . .	4-3	4-3
	Launch Effects Trainer. . . . .	4-4	4-5
	IR Transmitter. . . . .	4-5	4-7

LIST OF ILLUSTRATIONS

<u>Number</u>	<u>Title</u>	<u>Page</u>
1-1	DRAGON System Training Equipment . . . . .	1-3
2-1	Training Equipment-operational block diagram . . . . .	2-3
2-2	Monitoring Set-operational block diagram . . . . .	2-5
2-3	Monitoring Set AN/TSQ-TI-I - analog processing circuits schematics. . . . .	2-11
2-4	Range Counter-logic diagram. . . . .	2-29
2-5	Monitoring Set AN/TSQ-TI-I - digital processing circuits schematics. . . . .	2-31
2-6	Memory Circuits-logic liagram. . . . .	2-43
2-7	Miss Circuit-logic diagram . . . . .	2-45
2-8	Battery Charger/Regulator 1A1A1 - schematic and parts placement . . . . .	2-49
2-9	Circuit card assembly 1A1A1A2 Pre-regulator-schematic and parts placement. . . . .	2-53
2-10	Circuit card assembly 1A1A1A3 Evaluator/Charger-schematic and parts placement. . . . .	2-57

<u>Number</u>	<u>Title</u>	<u>Page</u>
2-11	Circuit card assembly 1A1A1A4 +13 volt Power Supply-schematic and parts placement. . . . .	2-61
2-12	Circuit card assembly 1A1A1A5 -13 volt Power Supply-schematic and parts placement. . . . .	2-65
2-13	Voltmeter Circuit 1A1A1A7A1 - schematic diagram. . . . .	2-69
2-14	IR Transmitter PS/M-block diagram. . . . .	2-73
2-15	IR Transmitter PS/M-schematic diagram. . . . .	2-75
2-16	Lamp Assembly HVPS-schematic diagram . . . . .	2-81
2-17	Lamp Assembly-schematic diagram. . . . .	2-82
2-18	IR Transmitter Power Control card-schematic diagram. . . . .	2-83
2-19	Mechanical Functions of the Trainer. . . . .	2-89
2-20	Electronic Functions of the Trainer. . . . .	2-91
2-21	Trainer Schematic . . . . .	2-93
3-1	Printed circuit card 1A1A2A1 - schematic and parts placement. . . . .	3-3
3-2	Printed circuit card 1A1A2A2 - schematic and parts placement. . . . .	3-9
3-3	Printed circuit card 1A1A2A3 - schematic and parts placement. . . . .	3-15
3-4	Printed circuit card 1A1A2A4 - schematic and parts placement. . . . .	3-19
3-5	Printed circuit card 1A1A2A5 - schematic and parts placement. . . . .	3-25
3-6	Printed circuit card 1A1A2A6 - schematic and parts placement. . . . .	3-33
3-7	Printed circuit card 1A1A2A7 - schematic and parts placement. . . . .	3-37
3-8	Relay panel 1A1A3 - schematic and parts placement. . . . .	3-41
3-9	Monitoring Set AN/TSQ-TI-I - electrical interface schematic. . . . .	3-43
3-10	Monitoring S t AN/TSQ-TI-1 - switch pin positions. . . . .	3-47
4-1	Battery Charger/Regulator 1A1A3 Receptacle Connector Preparation. . . . .	4-6

PART NUMBER CONFIGURATION STATUS TABLE

This table is provided to enable maintenance personnel to determine if all authorized configuration changes have been incorporated in the equipment. The table is organized in figure number sequence as arranged in this manual. Beside each equipment item listed you will find the part number history of the item. The latest part number will be listed first with previous part numbers following in descending order. After the part number history is a list of all applicable Modification Instructions (MI's) pertaining to the item. Maintenance personnel are urged to constantly refer to this table in order to keep their equipment up-to-date. Part numbers will be removed from the schematic diagrams by future manual changes. Therefore, the part number configuration status table will become your source for the latest part number information.

When manual change pages are published as a result of approved configuration changes, the TM change transmittal sheet will indicate the applicable MI(s) and the affected pages. Be sure to retain the old pages until the modification has been applied to all of your equipment then insert the new change pages.

FIG. NO.	ITEM	PART NO. HISTORY	APPLICABLE MI'S
2-3	Monitoring Set AN/TSQ-TI 1	10275575	----
2-8	Battery Charger/Regulator IAIA1	10278445/10278444	----
2-9	Circuit card assembly 1A1A1A2	10249972	----
2-10	Circuit card assembly 1A1A1A3	10249968	----
2-11	Circuit card assembly 1A1A1A4	10249980	----
2-12	Circuit card assembly 1A1A1A5	10249984	----
2-13	Voltmeter circuit 1A1A1A7A1	10278434	----
2-14	IR Transmitter	10399076	----
2-17	Lamp assembly	10225678	----
2-18	IR Transmitter Power Control card	10190246	----
2-19	Launch Effects Trainer M54	10275700	
2-21	L. E. T. Time Delay Card	10275757/10276623	07596A-40/1
3-1	Printed circuit card 1A1A2A1	10276201	----
3-2	Printed circuit card 1A1A2A2	10276590/10276106	----
3-3	Printed circuit card 1A1A2A3	10275585	----

FIG. NO.	ITEM	PART NO.	HISTORY	APPLICABLE MI'S
3-4	Printed circuit card 1A1A2A4	10696236		----
3-5	Printed circuit card 1A1A2A5	10219010		----
3-6	Printed circuit card 1A1A2A6	10219013		----
3-7	Printed circuit card 1A1A2A7	10276591/10275595		----
3-8	Relay panel 1A1A3	10275504		----

SAFETY SUMMARY

The following are general safety precautions that personnel must understand and apply during operation and maintenance.

**KEEP AWAY FROM LIVE CIRCUITS**

Operating personnel must observe safety regulations at all times. Do not replace components or make adjustments inside the equipment with high voltage present. Under certain conditions, dangerous potentials may exist when the power control is in the off position. To avoid injury, remove power and discharge and ground a circuit before touching it.

**DO NOT SERVICE OR ADJUST ALONE**

Under no circumstances should any person reach into the enclosure for the purpose of servicing or adjusting the equipment except in the presence of someone who is capable of rendering aid.

**RESUSCITATION**

Personnel working with or near high voltages should be familiar with modern methods of resuscitation.

The following are specific safety precautions which are printed elsewhere in this manual and are repeated here in similar terms for emphasis.

WARNING

Personnel must wear safety goggles when destroying the IR lamp assembly to prevent eye damage or loss of sight.



WARNING

In view of the toxic and volatile nature of the materials used in the application of adhesives, paints, and conformal coatings, insure the area of application has adequate ventilation. Avoid breathing fumes. Avoid skin and eye contact by wearing protective gloves and goggles. If contact occurs, wash with water and soap and report to a first aid station. Flammables must be kept away from flames, sparks, and excessive heat. Solvents shall be stored in and used from approved safety containers which shall be sealed when not in use. All cloths used for solvent cleaning operation shall be discarded into an approved container.

WARNING

Ensure that the cartridge chamber of the LET is empty prior to beginning any maintenance action.

WARNING

The lamp bulb in the IR source is pressurized to about 215 psi. Safety goggles shall be worn and a protective shield for the body (such as plexiglass panel) shall be used whenever disassembly beyond the filter retainers (i.e., within the housing) is necessary. If lamp bulb is to be handled, light gloves shall be worn. Failed bulbs shall be disposed of by enclosing them within a thick plastic bag before breaking with a tool with a flat surface such as a shovel. Disposal techniques similar to those for cathode ray tubes are recommended.

CAUTION

Unresolve Plus S. G. for removing conformal coating must be confined to the affected work area only. It attacks most plastics and must not be spilled on other parts.

CAUTION

If heat is used for curing conformal coating, do not exceed 250°F.



CHAPTER 1  
INTRODUCTION

---

## Section I. GENERAL

1-1. Purpose and Scope.

This manual contains a description of, and instructions for, the direct support and general support maintenance of the DRAGON System Training Equipment (fig. 1-1); AN/TSQ-T1 (Monitoring Set, Guided Missile System, Training), M54 (Launch Effects Trainer, Guided Missile), and M89 (Infrared Transmitting Set).

1-2. Troubleshooting Procedures.

Troubleshooting and testing of the training equipment and subassemblies will be accomplished by the procedures contained in chapter 3.

1-3. Forms, Records, and Reports.

All personnel and organizations responsible for operating and/or maintaining this equipment are also responsible for the preparation and disposition of appropriate forms, records, and reports.

1-4. Security Responsibilities.

a. The security classification of the DRAGON Weapon System Equipment is UNCLASSIFIED. Portions of data relative to the DRAGON System are classified.

b. The importance of security of classified material cannot be overemphasized. Security is an individual as well as a command responsibility.

c. Safeguarding of classified material will be accomplished in accordance with current directives.

1-5. Report of Equipment Manual Improvements.

Reports of errors, omissions, and recommendations for improving this publication by the individual user are encouraged. U. S. Marine Corps reports should be submitted on Form NAVMC 10772 in accordance with MCO 5600.41\_. All others should be submitted on DA Form 2028, Recommended Changes to Publications, and forward directly to: Commander, U. S. Army Missile Command, ATTN: DRSMI-SNPM, Redstone Arsenal, Alabama 35898

1-6. Shipment and Storage.

Data related to shipment and storage of the training equipment are contained in TM 9-6920-484-12.

## Section II. DESCRIPTION AND DATA

1-7. Physical Description of Training Equipment. (fig. I-1)

a. The DRAGON System Training Equipment consists of a lightweight shoulder-fired launch effects trainer (LET), a monitoring set (MTS), and an infrared transmitting set (IR transmitter). The LET uses an M64 grenade cartridge to simulate the M47 DRAGON round in backblast, recoil, weight loss, and sound level. The MTS incorporates controls and indicators which allow the instructor to monitor and recall the gunner's tracking performance. Operating power for the MTS is supplied by four 10-volt, rechargeable, nickel cadmium batteries. The batteries may be recharged by an internal battery charger. The IR transmitter emits an infrared signal which is used to establish signal contact between the tracker and the target. It operates from a 24 Vdc external power source. The IR transmitter may be vehicle-mounted.

b. The primary purpose of the training equipment is to train the gunner to acquire and accurately track a target, using the DRAGON tactical tracker.

c. Further physical data on the training equipment is contained in TM 9-6920-484-12.

1-8. Functional Description of the MTS.

a. The MTS may be used with the LET and IR transmitter to provide DRAGON proficiency training. It provides a means of observing a DRAGON gunner's ability to properly perform a firing exercise by converting electronic logic information into a visual readout presentation. This allows instructor evaluation of gunner performance.

b. The functional components of the MTS consist of a battery charger, four rechargeable batteries, seven printed circuit (PC) cards, a relay assembly, controls, indicators, and cable assemblies.

(1) The battery charger charges the nickel cadmium storage batteries from any of three external power sources. The battery charger and the MTS may be operated simultaneously to prevent depletion of the charge on the internal batteries.

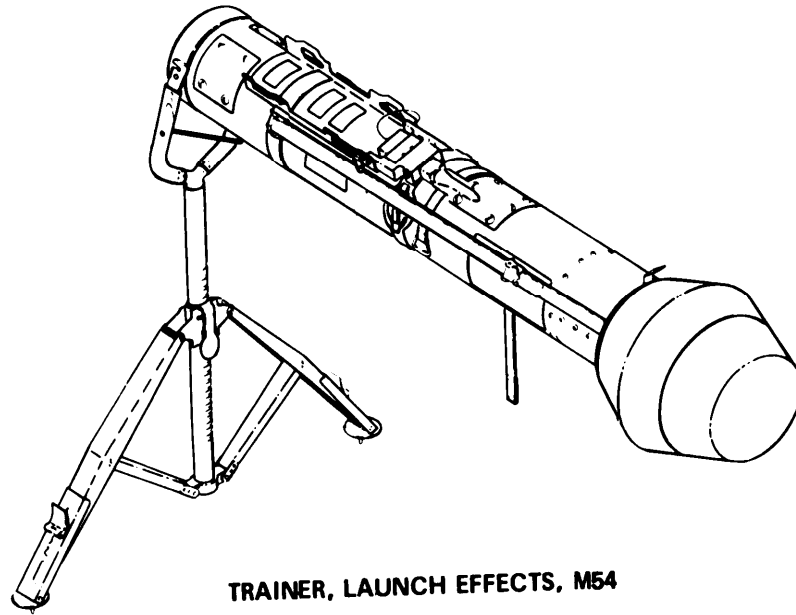

**TRAINER, LAUNCH EFFECTS, M54**

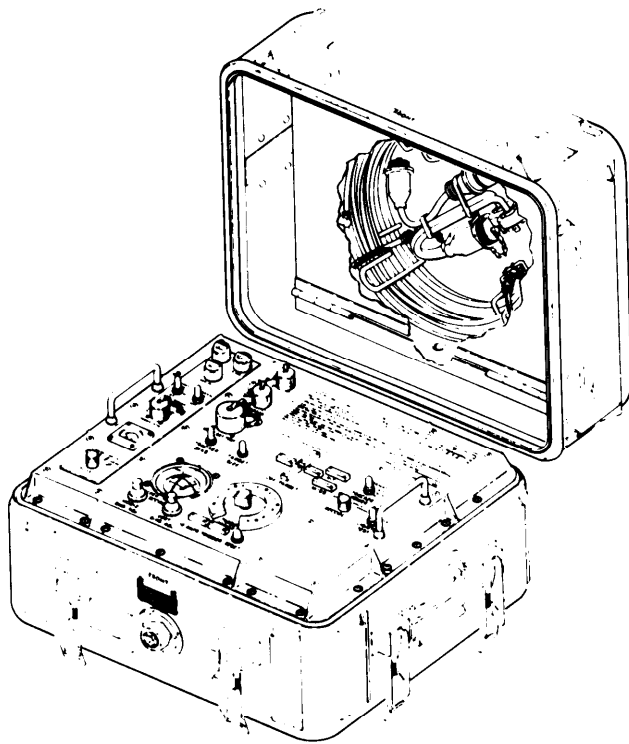

**MONITORING SET AN/TSQ-T1**

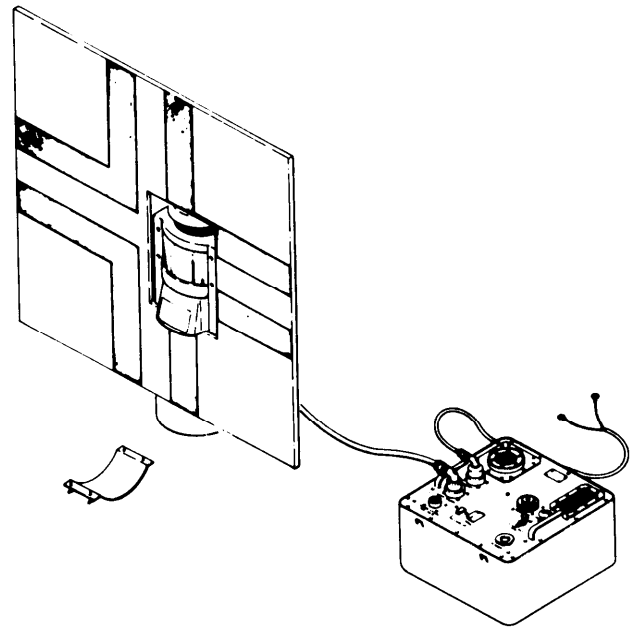

**INFRARED TRANSMITTING SET, M89**

**MS 161,508A**

**Figure 1-1. DRAGON System Training Equipment.**

(2) The four 10-volt nickel cadmium batteries have an available capacity of four amp-hours each. They are connected to supply +20 and -20 volts to the internal +13 Vdc and -13 Vdc supplies.

(3) The controls and indicators provide means of preestablishing various conditions for the MTS evaluation circuitry to match the training condition being simulated.

(4) The cable assemblies are used during battery charging operation and to connect the MTS to the LET.

(5) The PC cards and relay assembly generate the potentials for simulation of different target situations. Range sequenced evaluations of gunner performance are stored in memory circuits for recall at the end of each training shot. The memories are summed to provide a digital grade for assigning comparative grades to each performance.

#### 1-9. Functional Description of the LET.

a. The LET is a training device used to instruct DRAGON gunners in the deployment, techniques of fire, and firing positions of the DRAGON Weapon System.

b. The LET simulates the M47 DRAGON round. It uses an M64 grenade cartridge to provide the recoil, sound, and some of the launch characteristics of the tactical weapon. No projectile is launched from the LET.

c. Further data on the LET are contained in TM 9-6920-484-12.

#### 1-10. Functional Description of the IR Transmitter.

a. The IR transmitter is used in lieu of the IR source of an actual missile. It emits an IR signal used to establish contact between the tracker and the target.

b. The IR transmitter provides repetitious usage and mobility during training , exercises and can be mounted on any target vehicle.

c. Further data on the IR transmitter are contained in TM 9-6920-484-12.

### Section III. DEMOLITION TO PREVENT ENEMY USE

#### 1-11. Methods of Destruction.

If capture or abandonment of the training equipment to an enemy is imminent, the responsible unit commander may decide to destroy it. Based on this decision, the training equipment may be rendered inoperable by one of the following means:

a. Placing 1/2-pound of composition explosive in direct contact with the piece

to be destroyed and detonating it with a safety fuse.

- b. Weapon fire.
- c. Manually smashing with any available heavy object.
- d. Disassembly, scattering, and concealment.

WARNING

Personnel must wear safety goggles when destroying the IR lamp assembly to prevent eye damage or loss of sight.

1-12. Items to be Destroyed.

When the training equipment is to be destroyed, regardless of method, the following priority should be used:

- a. IR transmitter power supply/modulator.
- b. IR transmitter lamp assembly.
- c. MTS.
- d. LET.





CHAPTER 2  
THEORY OF OPERATION

---

2-1 I Operational Description of DRAGON Training Equipment. (fig. 2-1)

a. The training equipment consists of a launch effects trainer (LET), monitoring set (MTS), and infrared (IR) transmitter. The tactical tracker is used with the training equipment.

NOTE

The following description assumes use of the MTS with the LET and IR transmitter. Use of the MTS is not mandatory, however, and the LET may be utilized without it to simulate only firing characteristics. Operation of the LET is identical in either instance.

b. The gunner establishes a line of sight to the target utilizing the tracker telescope for target acquisition. Keeping the crosshairs on the target, the gunner depresses the safety and squeezes the trigger, initiating an electrical pulse which energizes the LET trigger relay. This provides a signal that initiates the time-delay assembly and activates control circuits in the MTS. The control circuits provide an enable signal to the analog processing circuits, momentary enable to the TRIGGER lamp, and power to the tracker. At 700 msec after trigger squeeze, the time-delay assembly activates the firing solenoid which generates the fire command signal. The fire command signal is then routed to the control circuits which change it to the first motion signal.

c. After power has been applied to the tracker and when it sees (diode senses) an IR source modulated at the proper frequency, the tracker generates a transmitter acquisition sum signal. This signal is applied to the transmitter acquisition circuit of the MTS, illuminating the IR XMTR lamp.

d. Activating the LET firing mechanism causes the hammer to strike the firing pin, discharging the cartridge and causing the recoil and sound effect.

e. During the firing run, the MTS analog processing circuits receive horizontal and vertical rate/position data inputs from the tracker. These inputs are applied to the comparator and scoring integrator circuits. Tracking information is displayed on the TRACKER INDICATOR SCORE meter as the firing run progresses.

f. Upon completion of the firing run, the TRACKER INDICATOR SCORE meter displays a summation of tracking errors (score). Depending upon error inputs, the HIT or MISS lamp is illuminated. When the MISS lamp is enabled, the RANGE SELECTOR switch may be manually rotated back through each position. This permits the decode and memory circuits to apply an enable signal to the appropriate ERROR INDICATOR lamp(s) for each range at which the error(s) occurred.

## 2-2. Operational Description of the MTS. (fig. 2-2)

a. The battery charger provides the capability of charging the batteries in the MTS from any one of three external power sources; 105-130 Vac 50-400 Hz, 190-230 Vac 50-400 Hz, or 18-30 Vdc.

b. The four 10-volt nickel cadmium storage batteries have an available capacity of four amp-hours each. They are connected to provide +20 and -20 volts to the internal +13 Vdc and -13 Vdc regulators.

c. The seven PC cards, in conjunction with the relay assembly and the control and indicators, can be divided into eight major blocks.

(1) The manual inputs to the control circuits are range selection, target size, horizontal and vertical bias, and tracker power. The range selector synchronizes the range program to the simulated missile firing. Target size is applied to the function generator to program the proper parameters for type of target being engaged. Horizontal and vertical bias is applied to the analog processing circuits to remove the effects of offset of the aim point from the IR source. Tracker power enables the control circuits to supply tracker power during firing runs and bore-sight alignment.

(2) The trigger input to the control circuits is from the LET at trigger pull. This activates the control circuits necessary to provide the following stimuli; an enable signal to the analog processing circuit, transfer of tracker indicator score input, tracker first motion and tracker power, a reset pulse to the decode and memory circuit, and momentary enable to the TRIGGER lamp.

(3) The fire command input to the control circuit occurs when the LET first motion limit switch closes (700 msec after trigger pull). The control circuitry provides an enable signal to the clock counter and a first motion signal to the function generator.

(4) Upon completion of the firing run, as determined by range selection, the decode and memory circuits supply a stop signal to the control circuits. Upon receipt of the stop signal, the control circuitry applies a stop signal to the

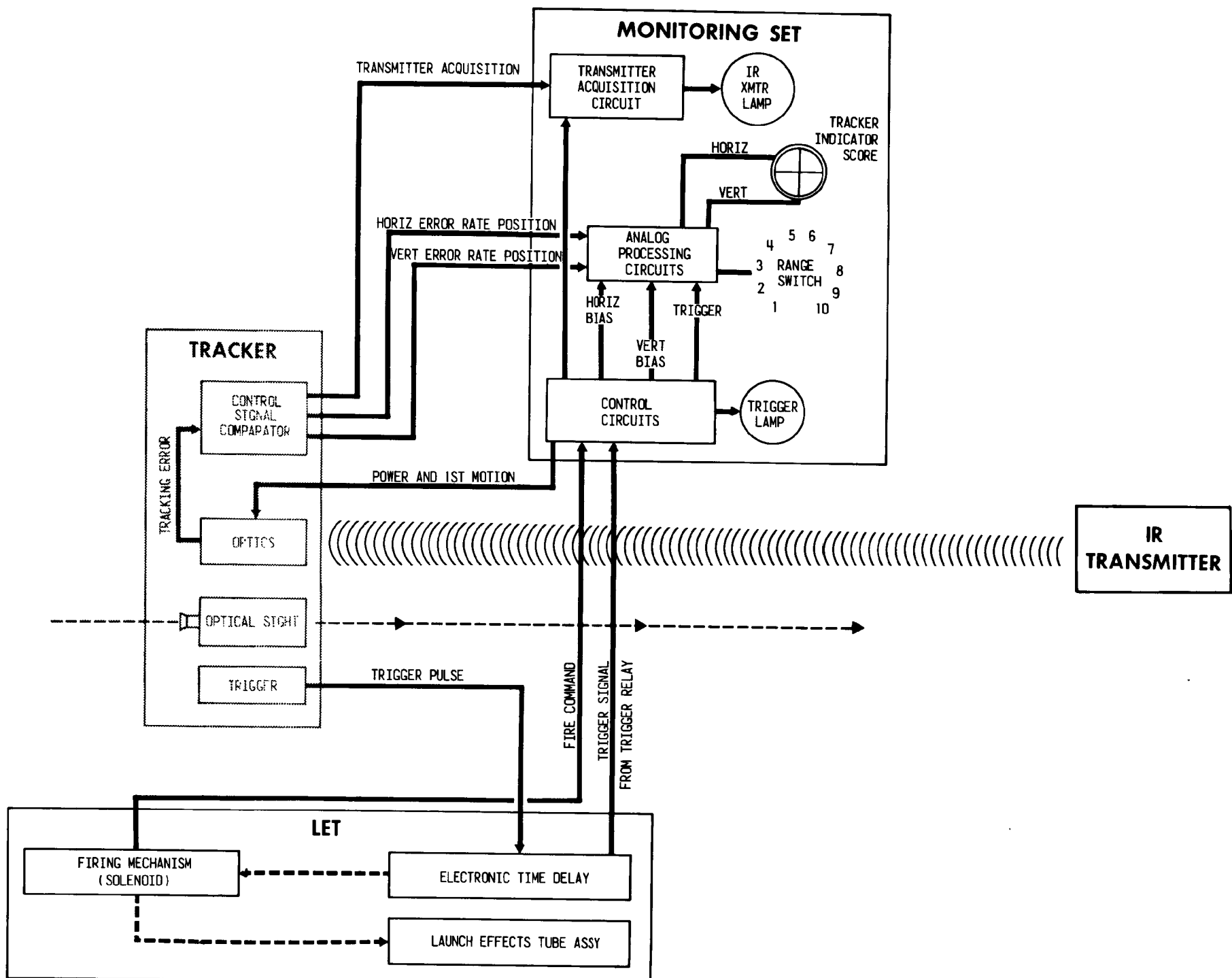

MS 161,509

Figure 2-1. Training Equipment-operational block diagram.



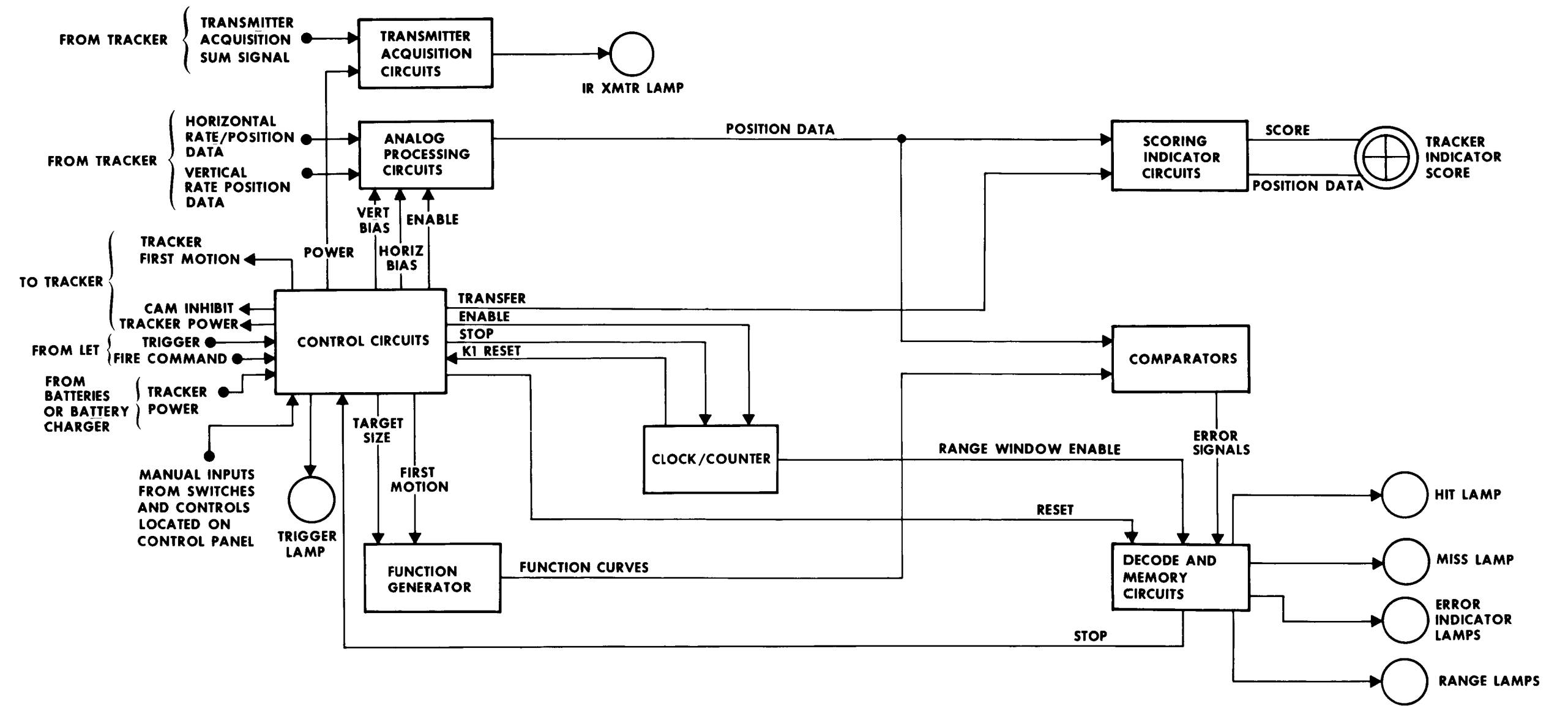

MS 161,510

Figure 2-2. Monitoring set-operational block diagram



clock/counter which in turn supplies a reset signal to control circuit relay K1.

(5) The cam inhibit output from the control circuits is applied to the tracker during boresight alignment for ranges less than 300 meters.

(6) In addition to inputs from the control circuits, the analog processing circuits receive horizontal and vertical rate position data inputs from the tracker. These inputs consist of linear data which is converted to angular data and applied to the comparators and scoring integrator circuits.

(7) When the tracker indicator score input is transferred to position data (at trigger pull), tracker information is displayed as the run progresses. Upon completion of the firing run, the tracker indicator score input is transferred to score, changing the display to a summation of tracking errors (score).

(8) The function generator receives target size and first motion inputs from the control circuits to initiate and establish parameters for horizontal and vertical function curves. These function curves are applied to the comparators.

(9) The comparators compare the position data inputs from the analog processing circuits to the function curves from the function generator. When position data indicates that tracker line-of-sight has deviated from the aim point more than the allowable amount established by the function generator, appropriate error signals are generated and applied to the decode and memory circuits.

(10) Upon receipt of an enable signal from the control circuits (at fire command), the clock/counter begins generating range window enable signals. These signals are applied to the decode and memory circuits, causing the error signals to be stored in the appropriate range segment memory circuit and range lamp enable signals to be generated. Upon completion of the firing run, either a HIT or MISS lamp enable signal is generated and a stop signal is applied via the control circuits to the clock/counter. The clock/counter then applies a reset signal to control circuit relay K1. When the MISS lamp is enabled, the RANGE SELECTOR switch is manually rotated back through each position. This permits the decode and memory circuits to apply an enable signal to the appropriate ERROR INDICATOR lamp(s) at each range in which errors occurred.

(11) When the tracker sees an IR source modulated at the proper frequency, it generates a transmitter acquisition sum signal which is applied to the transmitter acquisition circuit. When this signal is of sufficient amplitude to overcome the threshold of the transmitter acquisition circuit, an enable signal is applied to the IR XMTR lamp.

### 2-3. Operational Description of the LET.

a. The LET, in order to provide real weapon familiarity, must simulate or imitate characteristics of the tactical weapon. The LET looks like the tactical weapon with a few minor exceptions.

(1) The biped on the LET is ruggedized to increase its useful life.

(2) The LET has an instruction plate which outlines LET operation.

(3) The launcher tube has cover plates to allow battery replacement, and access for repair and disassembly.

b. A tactical tracker is used with the LET to further enhance the real weapon training familiarity. The electrical pulse generated by the tracker trigger initiates an internal time delay which ultimately allows the discharge of an M64 grenade cartridge. The sound and recoil simulation prepares the gunner for real weapon firing. The LET may be used with or without the MTS. For additional operational description of the LET, refer to TM 9-6920-484-12.

### 2-4. Operational Description of IR Transmitter.

a. The IR transmitter consists of three assemblies: power supply/modulator, target source, and target board assembly.

(1) The power supply/modulator is powered by the target vehicle's 24-volt battery. The power supply/modulator then provides the operating power to the target source. The lamp is started by the high voltage power supply in the target source. When the lamp ignites, a sensing circuit in the power supply/modulator deactivates the lamp starting circuit. A keep-alive circuit then maintains a constant two amps DC to the lamp. A power control circuit maintains lamp power at a constant 300 watts.

(2) The target source consists of the IR lamp, three reflectors, the IR filter, a quartz window, a protective cover, a high voltage power supply, and a blower assembly. The lamp provides the IR energy for missile in-flight simulation. The three reflectors focus the IR for transmission to the tracker. The IR filter limits the visible light so that it will not distract the gunner during a training exercise. The quartz window protects the filter and lamp. The protective cover protects the quartz window when the transmitter is not in use. The high voltage power supply provides a 15,000-volt starting potential to the starter electrode of the lamp. This high potential causes ionization of the gas which ignites the lamp. The blower assembly and its associated inverter cool the lamp to prevent overheating and premature burnout.



(3) The target board is a one square meter target, which is bolted onto the target source support. It has a red cross on a white background to provide a gunner aim point.

b. The target mounting kit consists of a pedestal, a universal adapter plate, four cargo slings, and associated hardware. The pedestal is attached to the universal adapter plate, which is attached to the target vehicle using the appropriate holes. The IR transmitter is then attached to the pedestal by a clamp. The clamp is loosened each time the target is rotated for a left-to-right or right-to-left crossing for moving target training.

## 2-5. Electrical and Electronic Functions of the MTS.

a. The discussion of the MTS circuitry is arranged according to circuit function. PC cards are identified by module designators.

b. The analog processing circuits (fig. 2-3) are composed of the divide network A2A7, filter assembly A2A1, function generator A2A2, and the error comparators A2A3.

### NOTE

Component locations on figure 2-3 are indicated in the data below by the zone locations in parentheses.

(1) The function of the divide network is to divide vertical and horizontal error signals by the simulated tracker range equation, thereby converting linear data to angular data.

(2) When the LET trigger activate switch opens, [at  $T_s$  (trigger pull)], the ground connection is removed from the cathode of A7CR10 (A17). This permits the potential at the junction of A7CR10 and A7VR1 to go in a positive direction. When this potential reaches approximately +7 Vdc, A7VR1 conducts, coupling a positive pulse through A7C15 which fires SCR A7Q10. When A7Q10 fires, relay K1 (B18) is set by current flow in the L coil. When K1 is set, it latches and can be reset only by energizing the R coil.

(3) Current flow through K1-L coil and A7R61 (B17) charges A7C15 to approximately +7 Vdc. This back biases A7VR1, which prevents triggering of A7Q10 by relay contact bounce or when the LET is rearmed. Discharge time of A7C15 (through A7R60, K1-L coil and A7R61) is approximately 10 seconds.

(4) At  $T_s$  (K1 energized), -13 Vdc is applied through K1-D contacts (A18), A4CR56 (A20), and A7R13 (D3) to the cathode of A7CR4. This voltage is applied

through A7CR4 to the gate of A7Q4. A7Q4 turns off, permitting time-delay integrator A7AR2 (D3) to begin generation of a linear output ramp voltage. At  $T_s + 314.0$  msec, the ramp voltage becomes greater than the threshold of comparator A7AR3 (C3). At this point, the output of A7AR3 goes from positive saturation to negative saturation.

(a) The output of A7AR3 is applied through A7CR5 (B3) to the gate of A7Q5. When A7AR3 goes negative, A7Q5 turns off. This causes integrator A7AR4 (A4) output to go positive at a rate established by the reference voltage at the output of A7AR1 (A3) (-0.5 Vdc). The time constant of A7R9 (A3), A7R10, and A7C6 establishes the rate at which the integrator output changes.

(b) The output of A7AR4 increases at a linear rate, charging A7C6, until  $T_s + 2.0$  seconds. At  $T_s + 2.0$  seconds, the charge on A7C6 overcomes the threshold of comparator A7AR5 (A6). A7AR5 output goes negative, which turns off A7Q1. This adds A7R7 and A7R8 to the input circuit of A7AR4, decreasing its output. This decreases the charging rate of A7C6, decreasing the slope angle of the output waveform.

(c) The output of A7AR4 increases linearly until  $T_s + 6.0$  seconds, at which time the charge on A7C6 overcomes the threshold of comparator A7AR6 (B4). The output of A7AR6 goes positive, turning on A7Q6 which then turns on A7Q2. This connects A7R11 and A7R12 in parallel with input resistors A7R7, A7R8, A7R9, and A7R10; reducing the input resistance of A7AR4.

(d) The output of A7AR4 increases, increasing the charging rate of A7C6 and, in turn, the slope angle of the output waveform. The output of A7AR4 again increases at a linear rate until  $T_s + 11.3$  seconds. At  $T_s + 11.3$  seconds, the charge which is developing on A7C6 is sufficient to overcome the threshold of comparator A7AR7 (A5). The output of A7AR7 goes negative, turning off A7Q3 and halting the generation of the divide gain curve. The divide gain curve is a waveform whose amplitude/time characteristics closely simulate the tracker gain/time characteristics.

(5) The divide gain curve (output of A7AR4) is applied to the source of A7Q7 (C4). The output of A7Q7 is applied to buffer amplifier A7AR8. The output of A7AR8 is applied to the inverting input of comparator A7AR9. The noninverting input of A7AR9 is maintained at +200 mVdc. The output of A7AR9 is applied to high gain amplifier A7AR10. The output of A7AR10 is applied to the inverting input of comparator A7AR12. The signal applied to the noninverting input of A7AR12 is a sawtooth waveform from oscillator A7AR11. A7AR11 operating frequency is 4 kHz

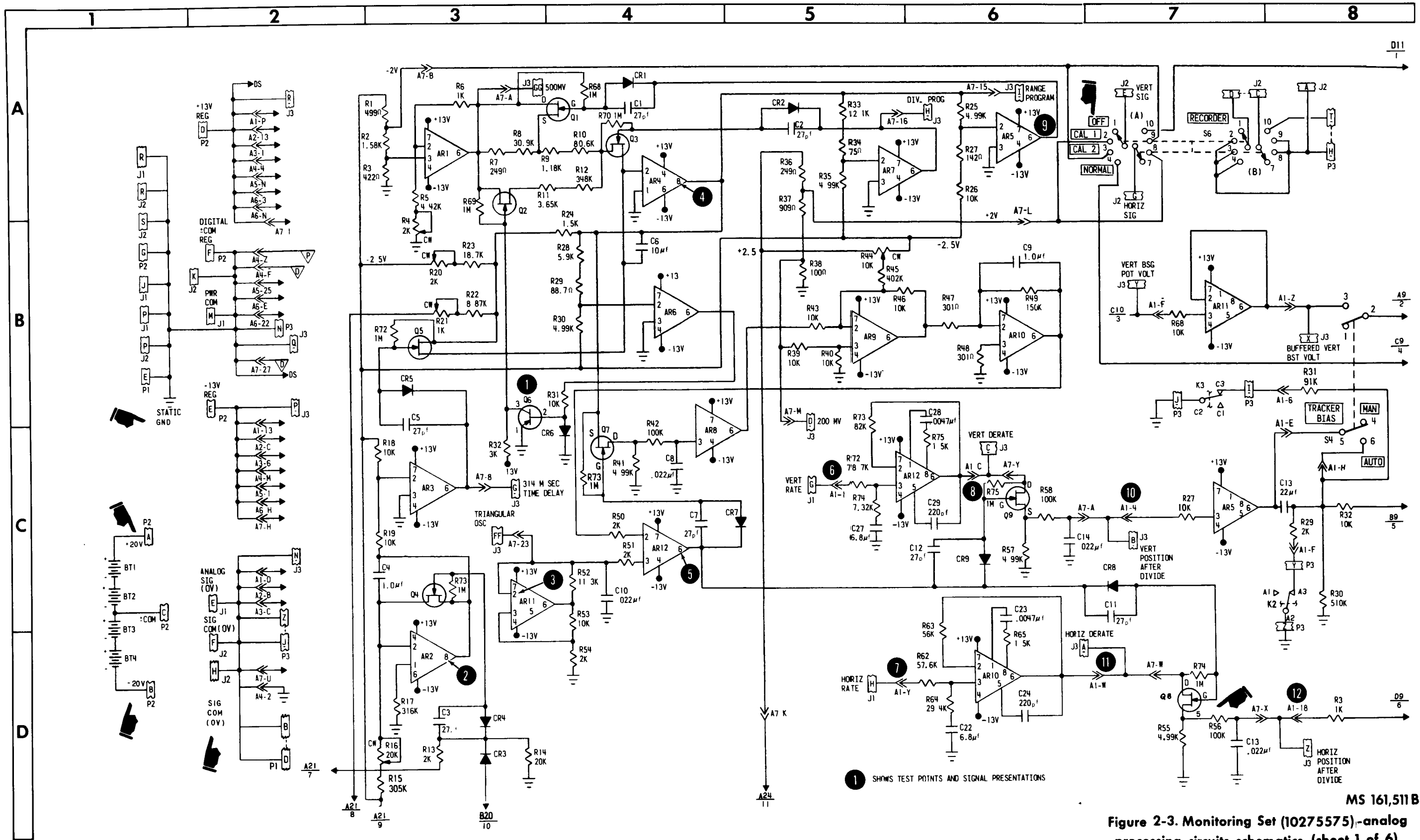

Figure 2-3. Monitoring Set (10275575)-analog processing circuits schematics. (sheet 1 of 6)



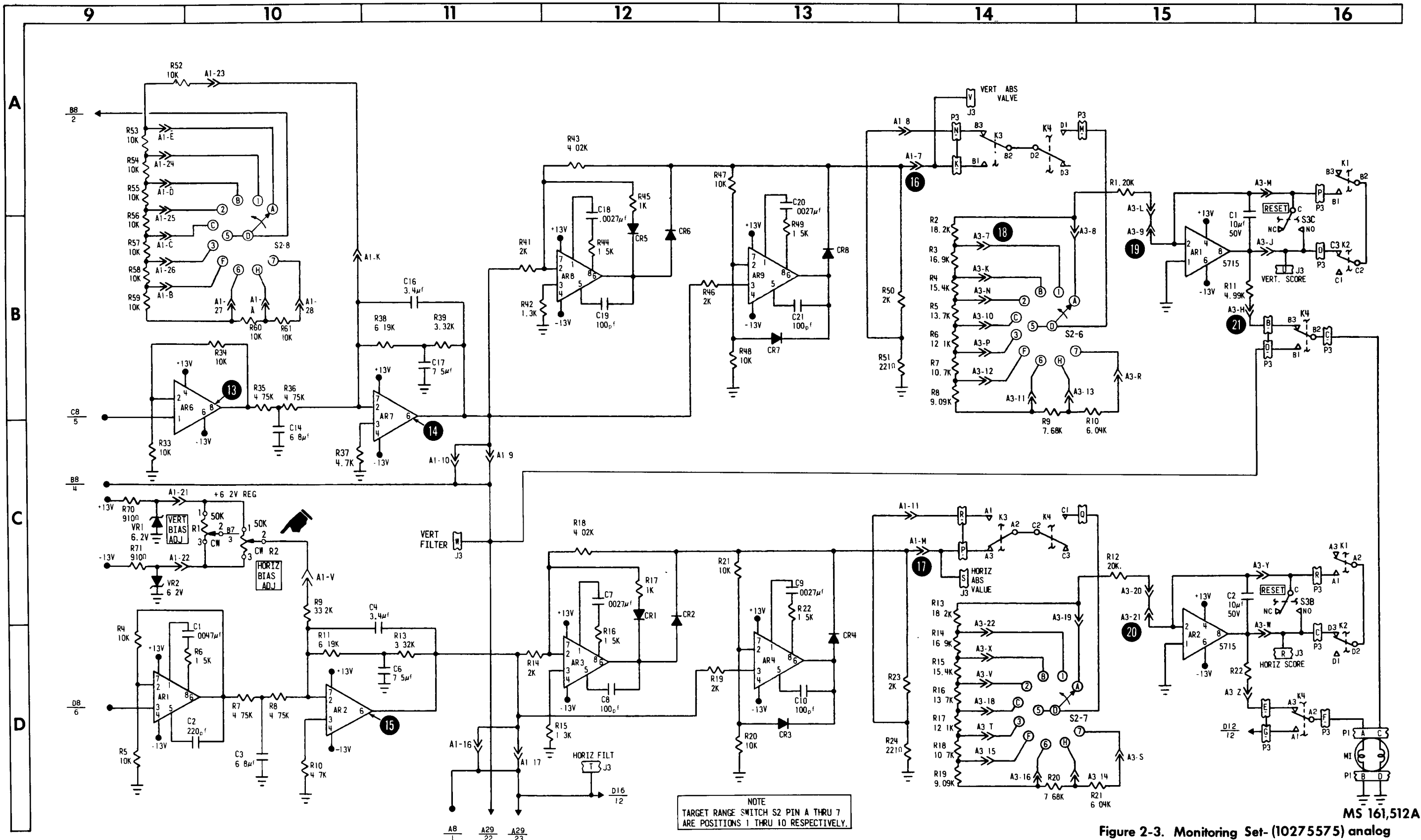
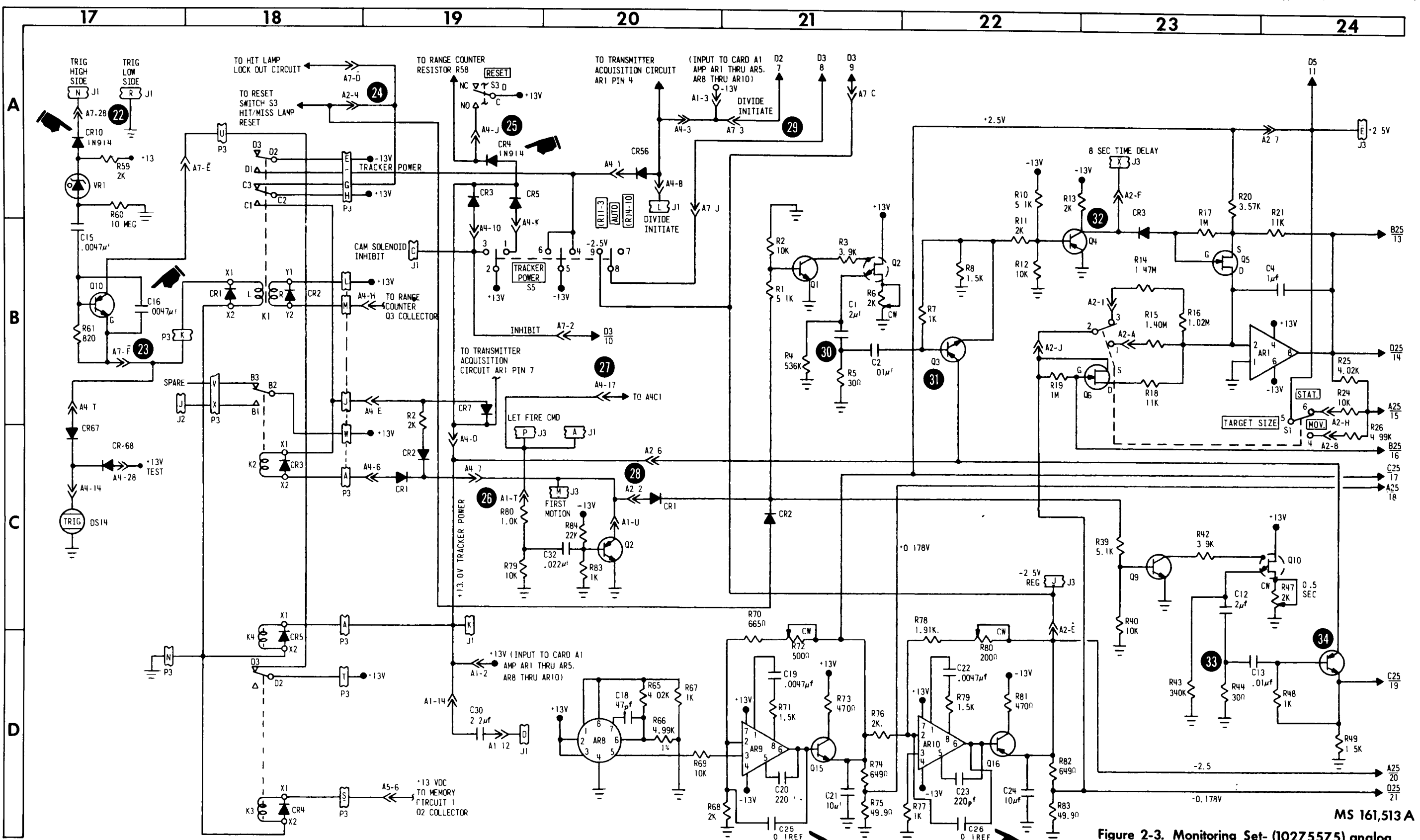

Figure 2-3. Monitoring Set-(10275575) analog processing circuits schematics (sheet 2 of 6)

MS 161,512A



C2



MS 161,513 A

Figure 2-3. Monitoring Set- (10275575) analog processing circuits schematics (sheet 3 of 6)





C2

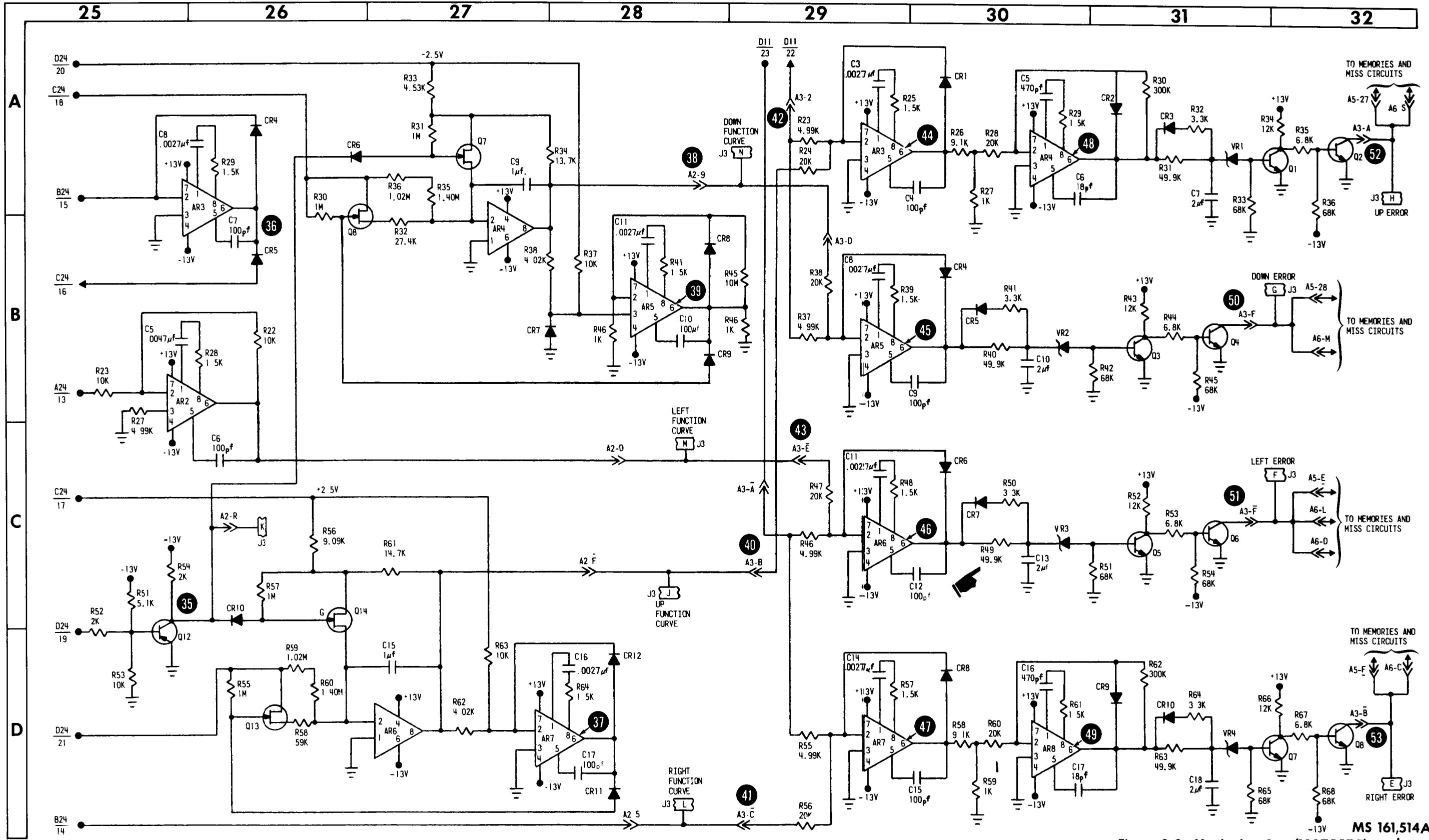

MS 161,514A  
Figure 2-3. Monitoring Set-(10275575) analog processing circuits schematics (sheet 4 of 6)



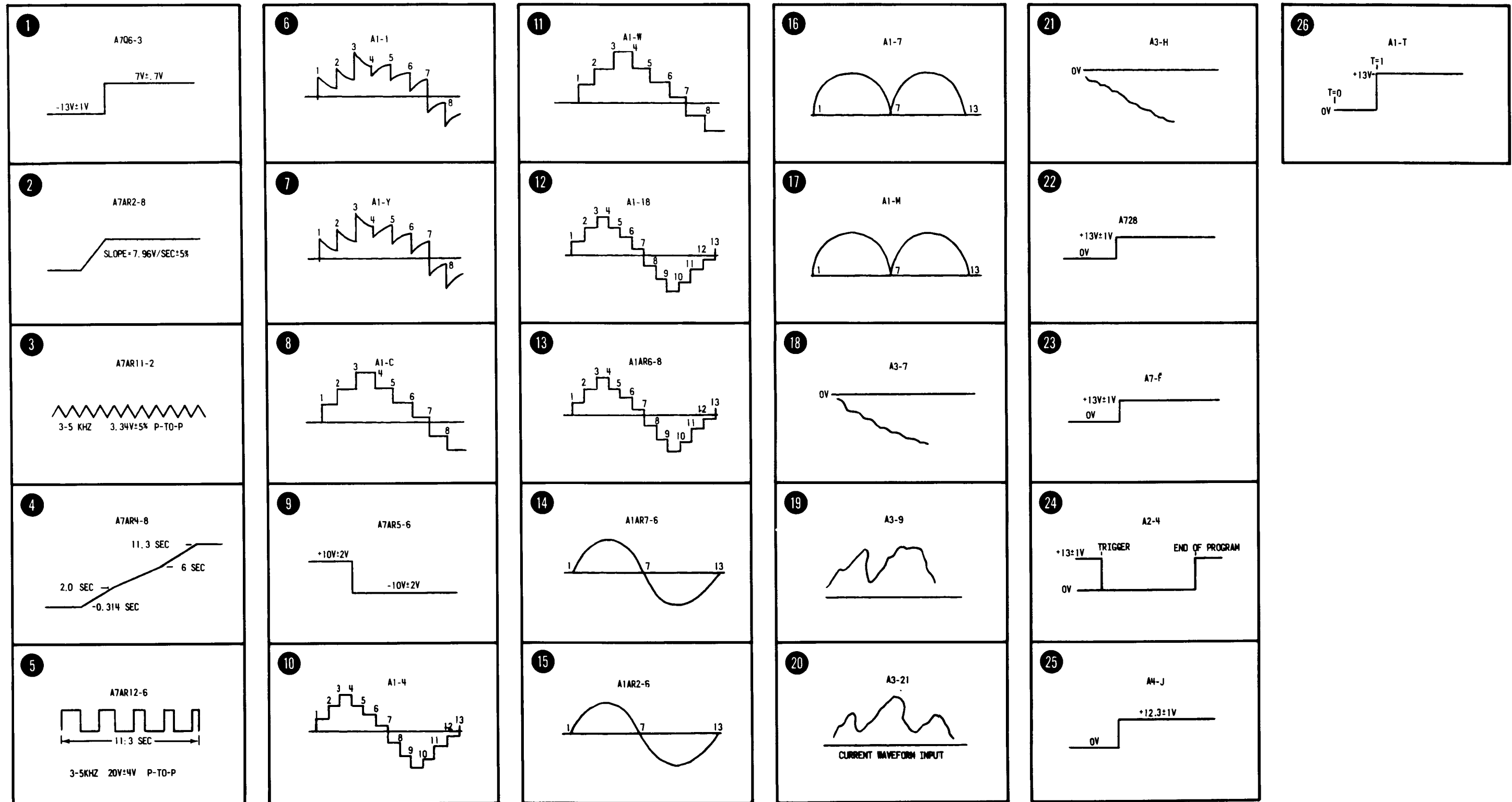

Figure 2-3 Monitoring Set-(10275575) analog processing circuits schematics (sheet 5 of 6)







nominal . The output of A7AR12 is a pulse-width modulated square wave. Frequency is determined by the frequency of A7AR11 and pulse width is determined by the amplitude of A7AR10 output. A7AR12 output is applied through A7CR7 and A7C7 to the gate of A7Q7, thus completing the loop by controlling the input to A7AR8. The output of A7AR12 is also applied through A7CR8 and A7C11 to the gate of A7Q8, and through A7CR9 and A7C12 to the gate of A7Q9.

(6) The input voltage to A7Q7 (C4) determines the duty cycle of the divide circuit. Therefore, when the range equation is applied to the input of A7Q7, the duty cycle is such that the position signal from the tracker is divided by the range program. Horizontal and vertical position data are applied to the drains of A7Q8 (D7) and A7Q9 (C6), respectively.

(7) Filter assembly A2A1 consists of derate circuits, 5 Hz filter circuits, an X2 scaling amplifier, and absolute value amplifiers. The functions of the filter assembly are to remove rate data from the rate/position input signal, remove spurious noise from the position signal (after the divide network divides it by the range equation), provide error data to the comparators, and provide absolute error data to the TRACKER INDICATOR SCORE meter. The filter assembly incorporates both a vertical and horizontal channel. The operation of these channels is identical except for minor differences. Therefore, only the vertical channel will be discussed. Where differences in operation of the channels exist, explanations will be provided.

(8) The vertical rate/position input to the derate circuit is applied to an RC network comprised of A1R72 (C5), A1R74, and A1C27. Rate data consists of high frequency spikes on the position data waveform. A1C27 presents a low impedance to these spikes while presenting a very high impedance to position data. Position data signals at the junction of A1R72 and A1R74 are applied to buffer amplifier A1AR12. A1R72 resistance is 11 times that of A1R74; therefore, the input signal to A1AR12, compared to that across A1R72, is reduced by a factor of 11. (In the horizontal channel, the input is reduced by a factor of 2.)

(9) The output of A1AR12 is applied to the drain of A7Q9 (the output of the divide network drives the gate of A7Q9). The output of A7Q9 is filtered by A7R58 and A7C14 and then applied to buffer amplifier A1AR5. The output of A1AR5 is coupled through A1C13 (C8) and A1R32 to the input of X2 amplifier A1AR6 (B9). The output of A1AR6 is applied to low pass (5 Hz) active filter A1AR7. A1AR7 removes spurious spikes caused by tracker sampling. The output of A1AR7 is applied to the error comparators and to the absolute value scoring amplifiers A1AR8 (B12) and

A1AR9 (B13). A1AR8 passes positive going data, and A1AR9 inverts and passes negative going data. During range segment ONE, A1AR8 and A1AR9 output is applied through A1R50 and relay contacts K3-B3 and K4-D1 to the arm of TARGET RANGE switch S2-6. During range segments two through ten, K3 is energized and the output of A1AR8 and A1AR9 is applied through contacts K3-B1 and K4-D1 to the arm of S2-6.

(10) When operating in the manual mode (TRACKER BIAS switch S4 (B8) in the MANUAL position), the DC bias level at the input of A1AR7 is used to compensate for offset of the aim point from the IR source. The amplitude and polarity of the bias level is established by adjustment of R1 (VERT BIAS ADJ) (C10). A potential of +6.2 to -6.2 Vdc is maintained across R1. The wiper arm of R1 is connected through A1R68 to the input of buffer amplifier A1AR11. The output of A1AR11 is applied through S4 to the arm of S2-8. The output from S2-8 to the input of A1AR7 (C11) is through various series resistor combinations, depending upon the range selected.

(11 ) When operating in the automatic mode (S4 in AUTO position), the horizontal channel operates in exactly the same manner as in the manual mode. In the vertical channel, aim point offset bias is established automatically. The output of A1AR11 (B7) is removed from the input to A1AR7 (C11). The output of A1AR5 (C7) is applied to A1C13. This charges A1C13 through A1R29 and A1R30 to a level determined by the amount of aim point offset. At  $T_s + 0.7$  seconds (fire command), K2 is energized, which removes A1R29 from the circuit. Thereafter, the discharge path for A1C13 is through A1R30 only during range segment one. At range segment two, relay K3 is energized, connecting A1R31 in parallel with A1R30.

(12) The purpose of the function generator (A2A2) is to establish gunner error limit curves in both the horizontal and vertical plane.

(13) At  $T_s$  (trigger pull), +13 Vdc is applied through K1-C1 (A18), the coil of K2 (C18), A4CR1 (C19), A2CR1 (C20), and A2R1 (B21) to the base of A2Q1. A2Q1 turns on, which inhibits complimentary unijunction A2Q2.

(a) At  $T_s + 0.7$  seconds (fire command), +13 Vdc is applied to the gate of SCR A1Q2 (C20). A1Q2 turns on, which clamps the anode of A2CR1 to ground and turns off A2Q1 (B21). This removes the inhibit voltage from A2Q2, and A2Q2 begins a 0.8 second time-delay cycle. The duration of the time-delay is determined by A2C1 and A2R6.

(b) At  $T_s + 1.5$  seconds, A2Q2 conducts heavily, causing a positive going pulse at the junction of A2C1 and A2R5 which is coupled across A2C2 to the gate of SCR A2Q3. A2Q3 conducts, which turns on A2Q4. The output of A2Q4 is coupled through A2CR3 to the gate of A2Q5. A2Q5 turns off, allowing integrator A2AR1 (B23)



to begin charging at a rate of 16.25 volts per second through A2Q6 and A2R18, which is in parallel with A2R15 or A2R14/A2R16, depending upon the position of TARGET SIZE switch S1 (B23). A2AR1 output (the right function curve) is applied through A2R25 (B24), in parallel with +2.5 Vdc through A2R24 or A2R26 (depending upon the position of S1), to the input of A2AR3 (A25).

(c) At  $T_s + 1.8$  seconds or  $T_s + 1.9$  seconds (depending upon the position of S1), the output of A2AR3 goes negative. This turns off A2Q6 (B23) and causes A2AR1 to charge at a rate of 71.4 or 126.8 mv per second (depending on position of S1). A2AR1 continues to charge at this rate throughout the remainder of the program. The right function curve is taken from the output of A2AR1 and the left function curve is taken from the output of A2AR2 (B25).

(14) At  $T_s$ , A2Q9 (C23) is turned on in the same manner as A2Q1 (B21), which inhibits complimentary unijunction A2Q10 (C24).

(a) At  $T_s + 0.7$  seconds, A2Q9 is turned off in the same manner as A2Q1. This allows A2Q10 to begin a 0.5 second time-delay determined by A2C12 and A2R47. Upon completion of the time-delay cycle, A2Q10 conducts, causing a positive going pulse at the junction of A2C12 and A2R44, which is coupled through A2C13 to the gate of SCR A2Q11. A2Q11 conducts, which turns on A2Q12 (C25). The output of A2Q12 is coupled through A2CR10 to the gate of A2Q14, and through A2CR6 (A26) to the gate of A2Q7. A2Q14 and A2Q7 turn off, allowing integrators A2AR6 (D26) and A2AR4 (A27), respectively, to begin charging. A2AR6 charges at a rate of 3.09 volts per second through A2Q13, A2R58, A2R59, and A2R60. The output of A2AR6 is applied through A2R62 to the input of amplifier A2AR7.

(b) At  $T_s + 2.1$  seconds, the output of A2AR7 goes negative which turns off A2Q13. This causes A2AR6 to charge at a rate of 73.7 mv per second for the remainder of the program. The up function curve is taken from the output of A2AR6. A2AR4 (A27) charges at a rate of 6.5 volts per second. A2AR4 output is applied through A2R38 to the input of A2AR5 (B28).

(c) At  $T_s + 2.2$  seconds, the output of A2AR5 goes negative, which turns off A2Q8. This causes A2AR4 to charge at 73.7 mv per second for the remainder of the program. The down function curve is taken from the output of A2AR4.

(15) Regulator A2AR8 (D20), amplifier A2AR9, A2Q15, amplifier A2AR10, and A2Q16 make up a 0.178 Vdc and 2.5 Vdc voltage regulator. The voltage across a reference diode in A2AR8 is applied to the input of A2AR9. The output of A2AR9 drives the base of A2Q15. The regulated +2.5 Vdc output of A2Q15 is applied across voltage divider A2R74 and A2R75. The voltage at the junction of A2R74 and A2R75 is +0.178

Vdc. A2Q15 output is applied through A2R76 to the input of A2AR1O. A2AR1O output drives the base of A2Q16. The regulated -2.5 Vdc output of A2Q16 is applied across voltage divider A2R82 and A2R83. The voltage at the junction of A2R82 and A2R83 is -0.178 Vdc. A2R72 calibrates the +2.5 Vdc and +0.178 Vdc outputs. A2R80 calibrates the -2.5 Vdc and -0.178 Vdc outputs.

(16) The function of the error comparators (A2A3) is to compare the error input signals from the filter assembly to the parameters established by the function generator. When the amplitude of error signals exceeds the amplitude of the applicable function generator parameter, the comparator circuits generate an input to the memory circuits. The operation of the horizontal and vertical comparator circuits are identical. Therefore, only the horizontal (left and right) comparator circuits will be discussed.

(17) The left comparator circuit is comprised of operational amplifier A3AR6 (C29), A3CR7, A3VR3, A3Q5, A3Q6, and associated components. The positive polarity left function curve and horizontal error signals are applied to summing resistors A3R47 and A3R46 (C29) respectively. The voltage at the junction of these resistors is applied to the inverting input of A3AR6. Negative output voltages of A3AR6 are fed back to the input through A3CR6. Therefore, in its quiescent state and when error voltages of positive polarity are applied to A3R46, the output of A3AR6 is equal to one diode drop. When an error voltage of negative polarity is applied to A3R46, the potential at A3R46 and A3R47 becomes less positive. Because of the ratio of A3R46 and A3R47, an error voltage of more than 25% of the amplitude of the function curve voltage will saturate A3AR6 output. The output of A3AR6 is applied to an RC network comprised of A3R49 and A3C13. The time constant of this circuit is such that  $75.0 \pm 15.0$  msec are required for the charge on A3C13 to reach the break down voltage of A3VR3. When A3AR6 positive input is removed, A3C13 discharges fast through A3R49, A3CR7, and A3R50. When A3VR3 breaks down, positive voltage is applied to the base of A3Q5, turning it on. The output of A3Q5 goes in a negative direction which turns off A3Q6. When A3Q6 turns off, it removes the ground from the memory circuit input diodes.

(18) The right comparator circuit is comprised of operational amplifiers A3AR7 (D29) and A3AR8, A3CR1O, A3VR4, A3Q7, A3Q8, and associated components. The negative polarity right function curve and horizontal error signals are applied to summing resistors A3R56 and A3R55 (D29), respectively. The voltage at the junction of the resistors is applied to the inverting input of A3AR7. Positive output voltages of A3AR7 are fed back to the input through A3CR8. Therefore, in its quiescent

state, and when error voltages of negative polarity are applied to A3R55, the output of A3AR7 is equal to one diode drop. When an error voltage of positive polarity is applied to A3R55, the potential at A3R55 and A3R56 becomes less negative. This positive going signal causes A3AR7 output to go negative. Because of the ratio of A3R55 to A3R56, an error voltage of 25% of the amplitude of the function curve voltage will saturate A3AR7 and will be recorded as an error. The output of A3AR7 is applied to the inverting input of A3AR8. From this point on, the right comparator function is identical to that of the left comparator, as explained above.

c. The digital processing circuits are comprised of memory circuits and a range counter circuit. The memory circuits store scoring data dependent on gunner performance. The range counter circuits control the memory circuits as predetermined by the firing range programmed.

(1) The range counter circuits logic diagram is presented in figure 2-4. It consists of a control flip-flop, relaxation oscillator (clock), four-state ripple counter, and decoding matrix. The functions of these circuits are to enable the memory circuits at the proper times and in the proper sequence, and to supply reset pulses to the memory circuits and relay K1.

(a) The memory reset circuit is enabled by the trigger pulse or by manually depressing the RESET push button on the control panel.

(b) The fire command signal sets the control flip-flop which starts a 1 Hz clock. The clock pulse toggles flip-flop A. Thereafter, each flip-flop is toggled by the preceding flip-flop 1 output when the 1 output goes low. The binary logic of the decoding matrix is depicted in the truth table on figure 2-4. It should be noted that the least significant bit for range one code is the clock pulse. For succeeding range codes, flip-flop A contains the least significant bit.

(c) As each memory circuit is enabled and then disabled, it supplies a reset pulse to the range counter reset circuit. At the proper time (as determined by the range selected), the reset pulse is applied to the control flip-flop and to relay K1. The control flip-flop supplies a stop signal to the clock and reset to, the ripple counter.

(d) The range counter circuits are made up of discrete components (fig. 2-5). When a circuit is comprised of more than one identical stage or functional unit, only the first stage or unit will be explained.

## NOTE

Component locations on figure 2-5 are indicated in the data below by the zone locations in parentheses.

(e) At  $T_s$  (trigger pull), +13Vdc is applied from K1C contacts (A5), A4CR7 (A6), A4CR4 (A7) and A4R58 (A9) to A4C14. A4C14 couples a 5 msec positive pulse to the base of A4Q14. A4Q14 turns on, which turns off A4Q15, turning off A4Q16. Turning off A4Q16 resets the memory circuits. Memory circuits may also be reset by closing RESET switch S3 (A9), thus applying +13 Vdc to A4C14.

(f) At  $T_s + 0.7$  seconds, the LET fire command (+13 Vdc) is applied to the control flip-flop capacitor A4C1 (C2). A4C1 couples a positive pulse through A4R5 to the base of A4Q2. A4Q2 turns on, which turns off A4Q1, provides a ground to the wiper arm of A4R16 (C3), and removes back bias from A4CR17, A4CR20, A4CR30, A4CR40, and A4CR50. When A4R16 wiper arm is grounded, A4C4 (B3) begins to charge. When the charge on A4C4 reaches the trip point of complimentary unijunction A4Q4, it fires. This turns A4Q5 on momentarily. A4C4 discharges through A4Q4 and A4R17. A4Q4 then turns off and A4C4 begins to charge again. When A4Q5 turns on, it toggles the first flip-flop in the ripple counter by turning on A4Q6 (B4). When A4Q6 turns on, it turns off A4Q7. The counter remains in this state until A4Q4 fires again. When A4Q4 again momentarily turns on A4Q5, the first flip-flop is again toggled, turning A4Q7 on and A4Q6 off. When A4Q7 turns on, it toggles the next flip-flop. The remaining flip-flops in the counter are toggled in the same manner by the immediately preceding flip-flop.

(g) The range decoding matrix consists of ten AND gates. These gates are enabled by the outputs of the ripple counter flip-flops and, in the case of range one, gate the output of A4Q5 (B4).

(h) The reset pulses from range circuits one through ten are applied to TARGET RANGE switch S2-5, contacts A through 7, respectively. The arm of S2 applies the pulse from the selected contact through A4R7 (C2), A4C2, and A4CR11 to the base of A4Q2. This turns off A4Q2, turning on A4Q1, removing the ground from the wiper arm of A4R16 and back biasing A4CR17, A4CR20, A4CR30, A4CR40, and A4CR50. When A4Q2 turns off, it also removes the ground from the cathode of A4CR16 (D3), which allows the anode of A4CR15 to rise to +13 Vdc. This turns on A4Q3 (D1) which resets K1.

(2) Ten identical memory circuits are employed in the MTS. Memory circuits one through six are contained on PC card A5. The remaining four are contained on

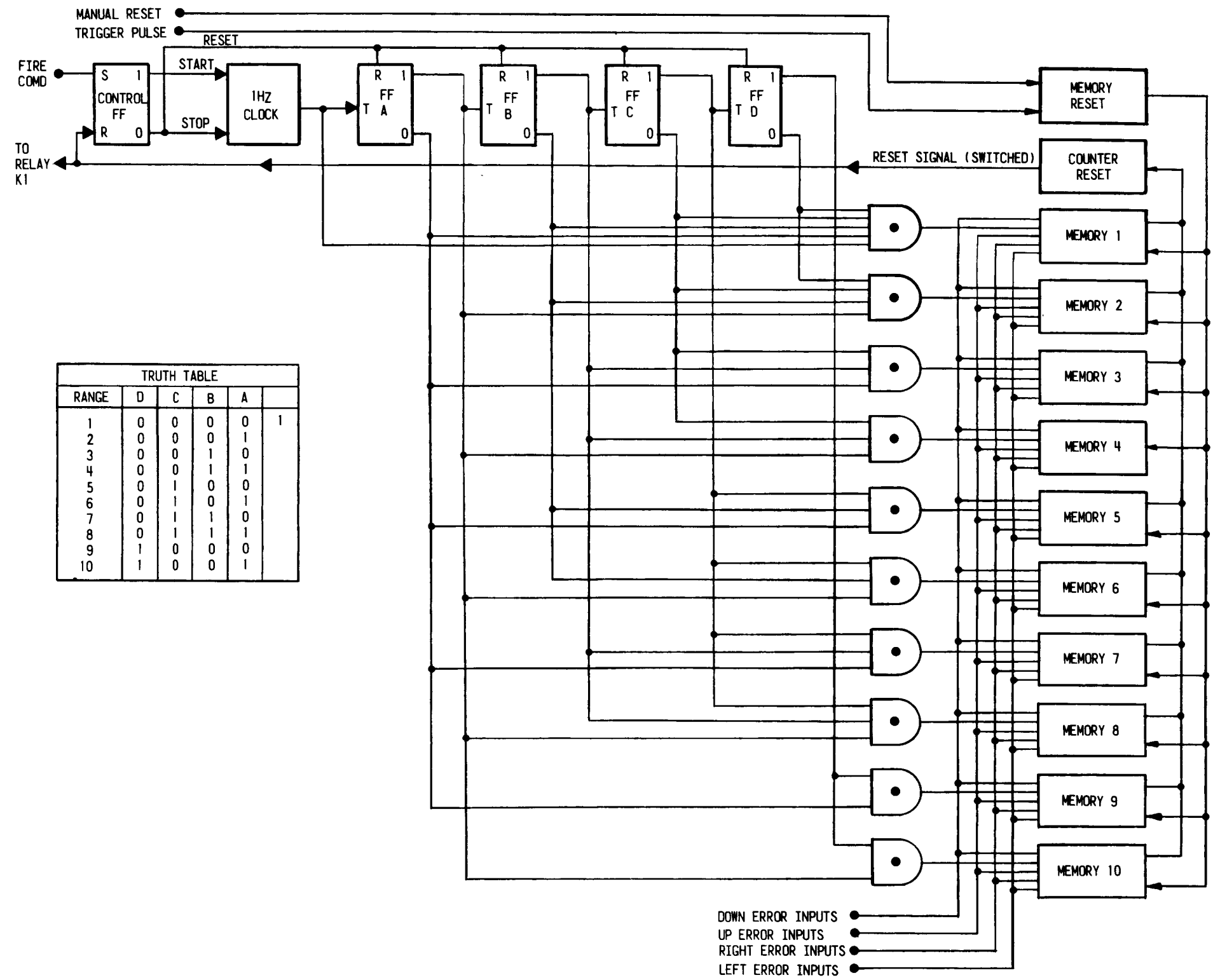

TRUTH TABLE					
RANGE	D	C	B	A	
1	0	0	0	0	1
2	0	0	0	1	0
3	0	0	1	1	0
4	0	0	1	0	1
5	0	1	0	0	1
6	0	1	0	1	0
7	0	1	1	1	0
8	0	1	1	0	1
9	1	0	0	0	0
10	1	0	0	0	1

Figure 2-4. Range Counter-logic diagram.



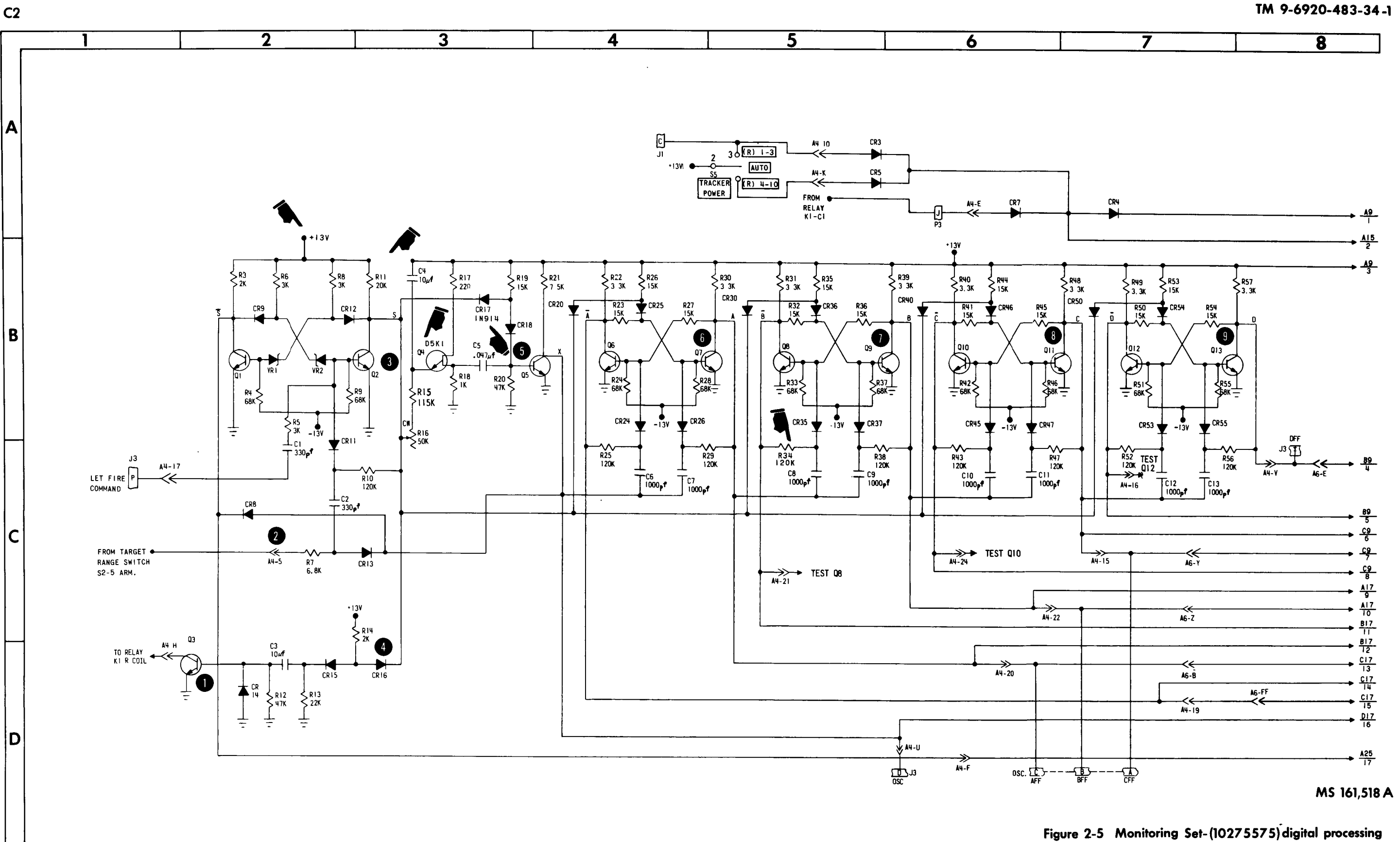

MS 161,518 A

Figure 2-5 Monitoring Set-(10275575) digital processing circuits schematics. (sheet 1 of 5)





C2

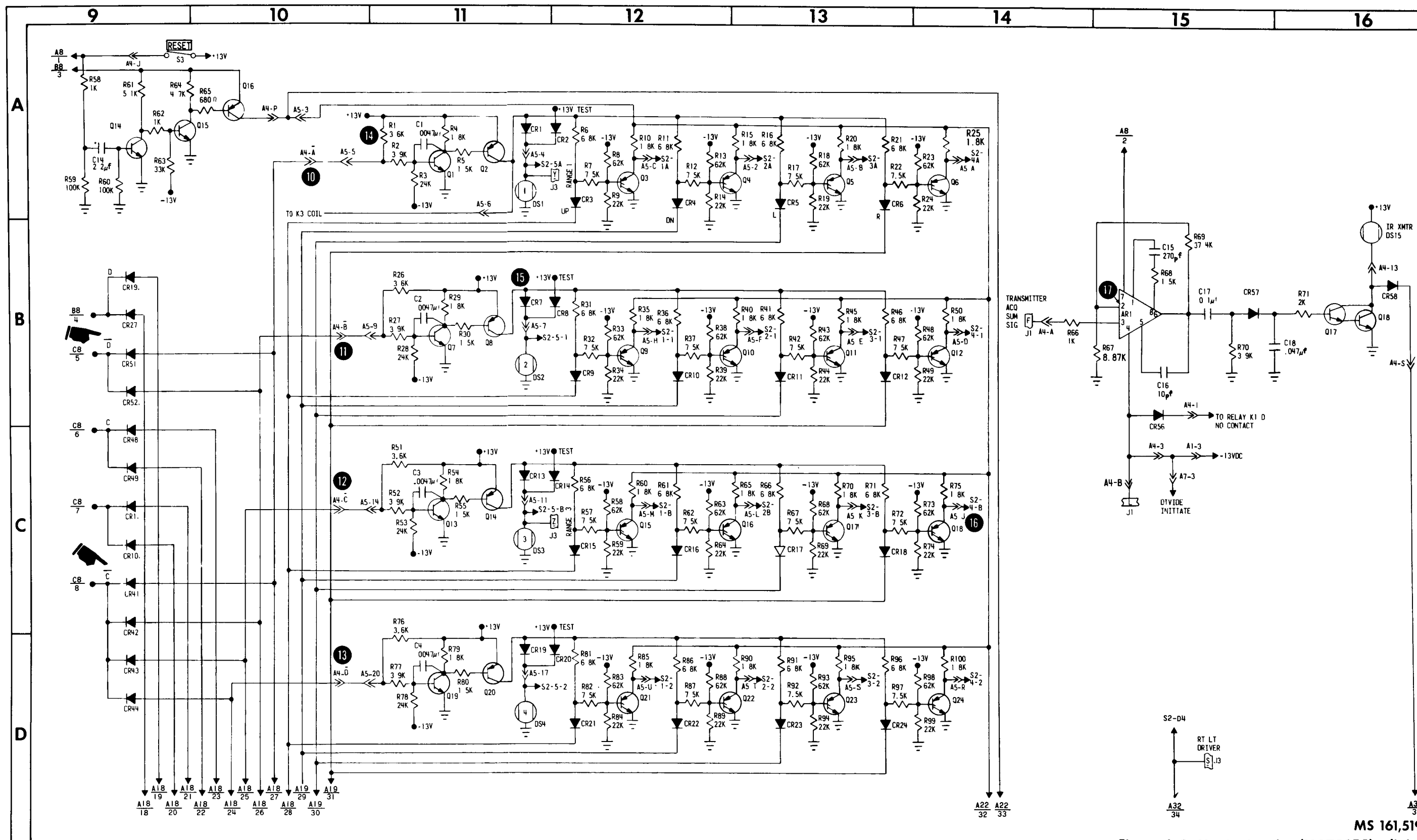

MS 161,519 A  
 Figure 2-5. Monitoring Set (10275575) -digital processing circuits schematics (sheet 2 of 5)  
 2-33/(2-34 Blank)



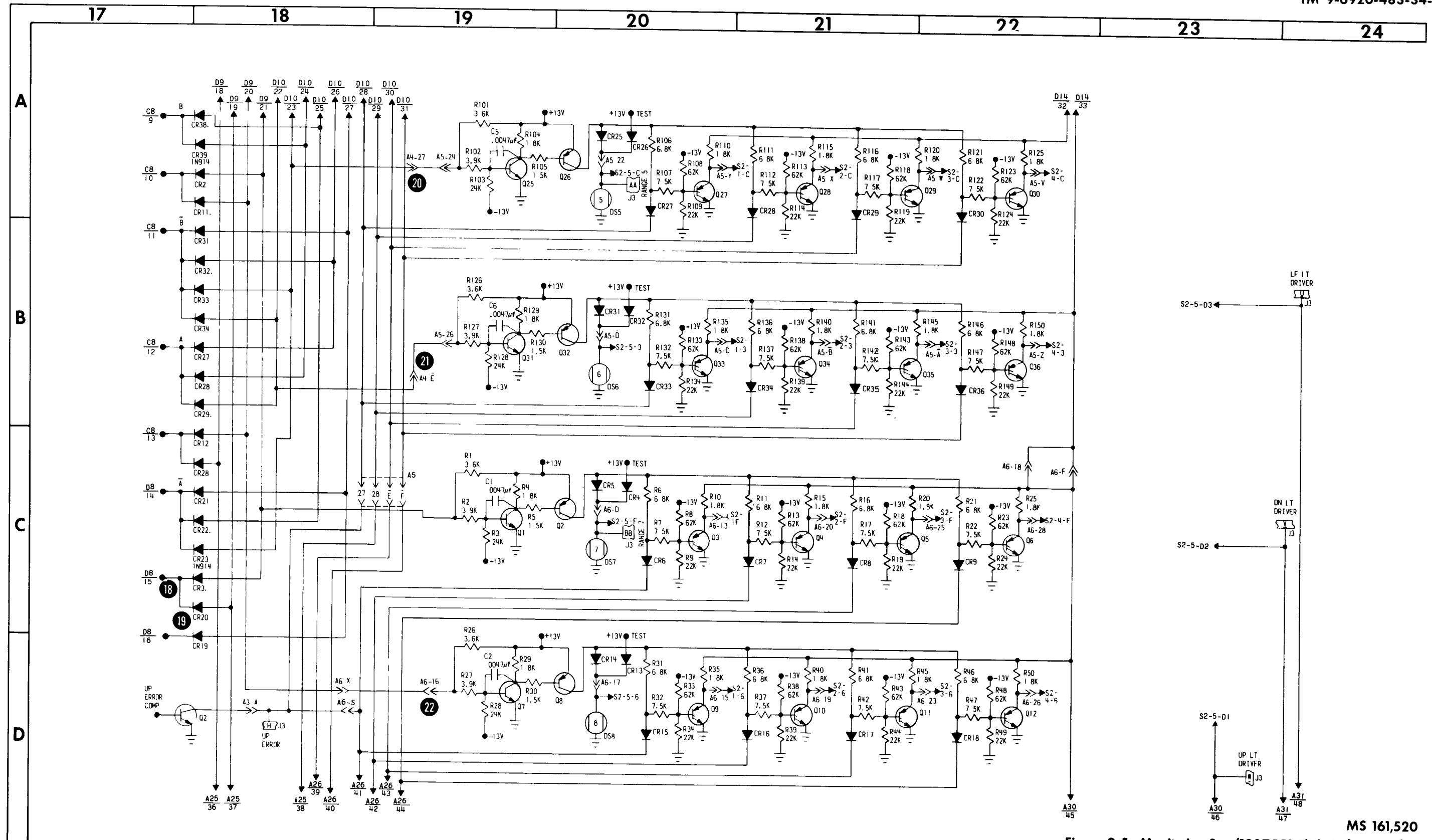

MS 161,520  
 Figure 2-5. Monitoring Set-(10275575) digital processing circuits schematics. (sheet 3 of 5)



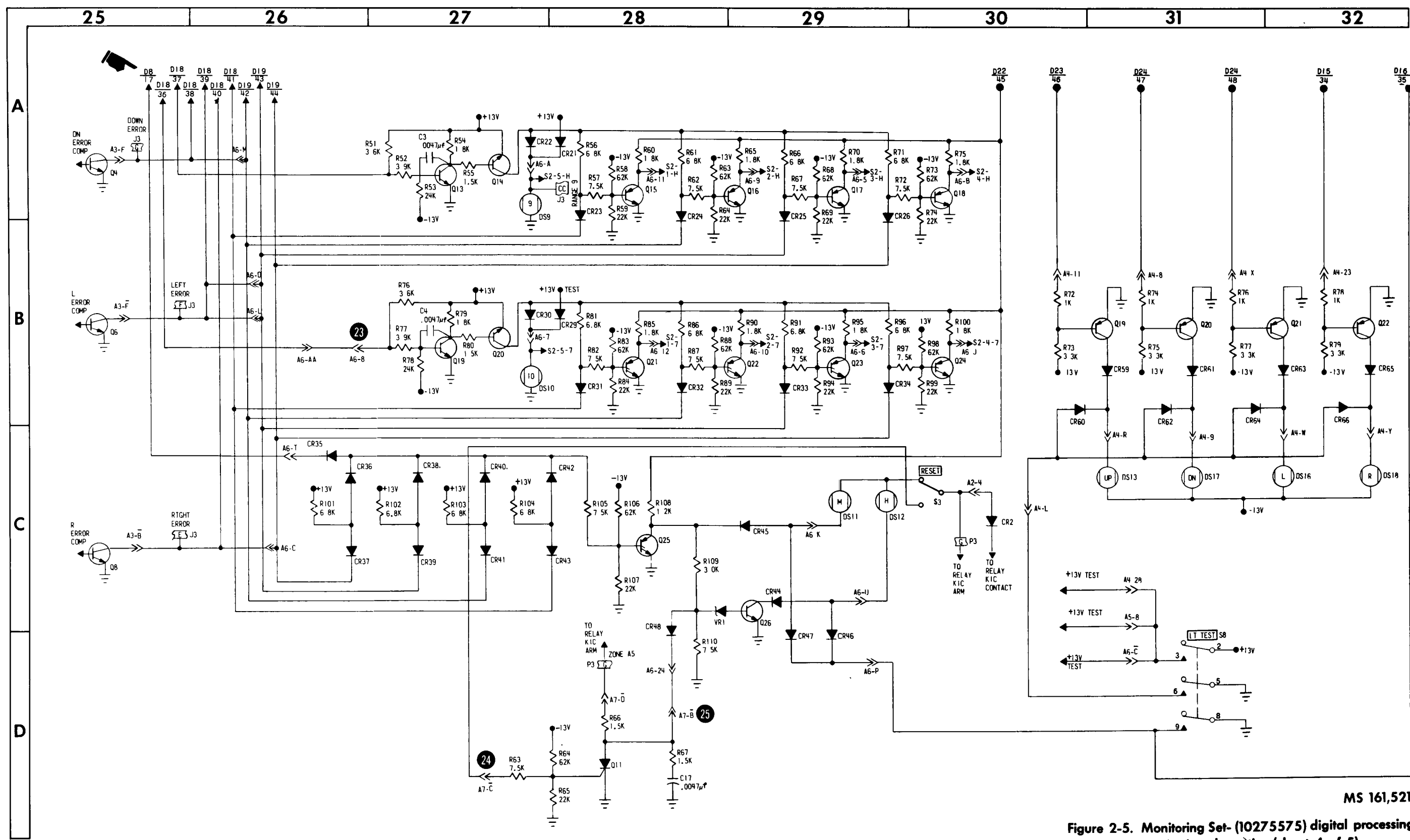

MS 161,521 A

Figure 2-5. Monitoring Set- (10275575) digital processing circuits schematics. (sheet 4 of 5)



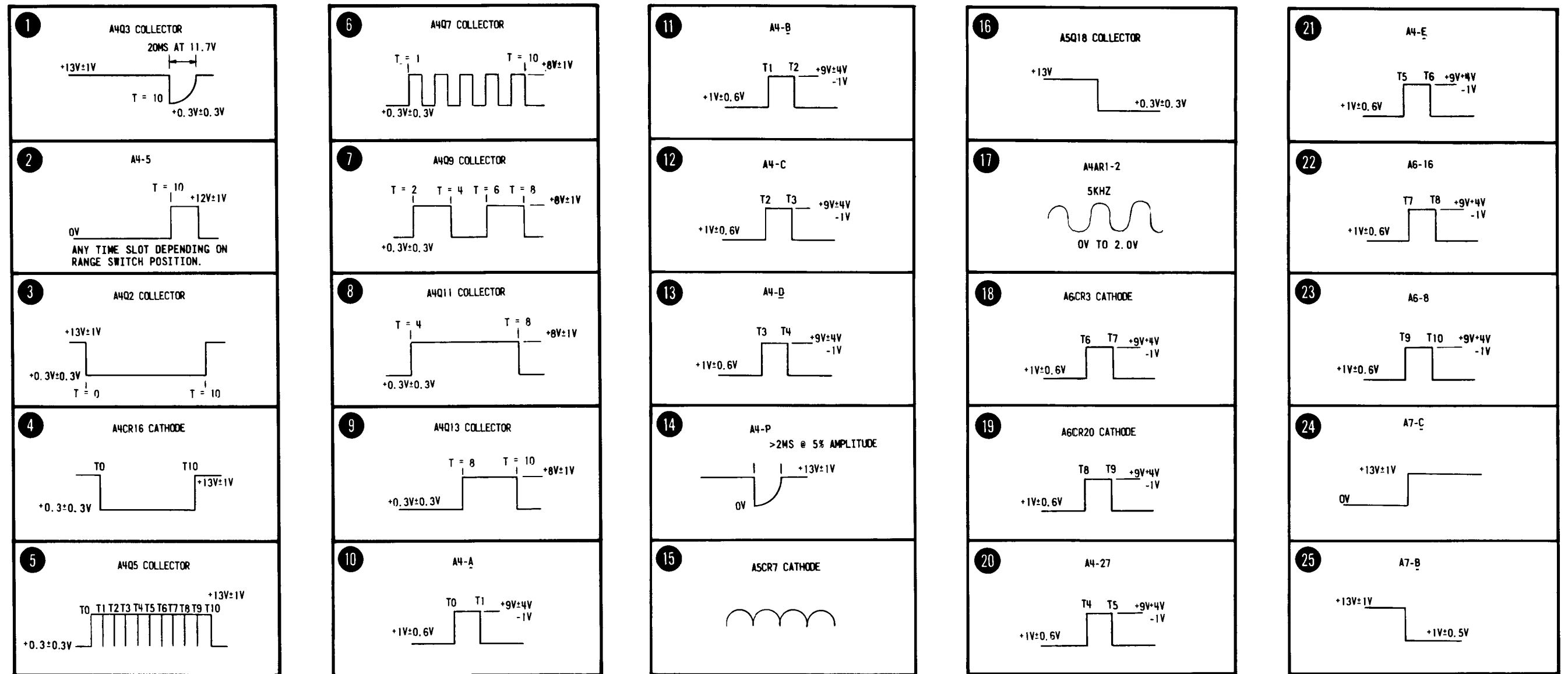

Figure 2-5. Monitoring Set-(10275575) digital processing circuits schematics.(sheet 5 of 5)





PC card A6. The function of the memory circuits is to store aiming errors. Distinction is made with regard to range segment and quadrant in which the errors occur; i.e., up, down, right, or left. When more than one error occurs in the same quadrant within the same range segment, only the first of these errors is stored. The memory circuits operating principals are identical. Therefore, only memory circuit one will be discussed. A logic diagram for the memory circuits is presented in figure 2-6.

(a) At  $T_s + 0.7$  sec, the range counter begins operation. The range counter decode circuits apply an enable signal to memory circuit one. This signal is applied to TARGET RANGE switch S2-5 pin A, range light one, K3 and the four AND gates. The output of each of the comparators is applied to its respective AND gate in each of the ten memory circuits. This signal, in conjunction with the signal from the range counter, enables the related SCR memory circuit(s). When SCR memory circuits are enabled, they remain enabled after the enabling signal is removed until a reset signal is applied. As the range counter continues through its program, memory two and subsequent memories are turned on and operate in precisely the same manner as memory one, with the exception that the clock signal is not applied to relay K3. The outputs of the SCR memories are applied to the appropriate deck and pins of S2. The duration of the firing run is determined by the setting of S2. When the range at which S2 is set is reached, a stop signal from the arm of deck five is applied to the range counter. S2 may then be rotated back through each position. As S2 is rotated back, the SCR memories are connected through deck one to the UP, deck two to the DOWN, deck three to the LEFT, and deck four to the RIGHT error light drivers. When connection is made to an enabled SCR memory, the appropriate lamp driver is on, which illuminates the related lamp. The SCR memories are reset by a reset signal from the range counter at trigger pull, or when the reset switch is activated.

(b) The memory circuits are made up of discrete components (fig. 2-5). The four AND gate SCR memories in each circuit are identical. Therefore, only the Up error circuit will be discussed.

(c) At  $T_s + 0.7$  seconds, the positive enable signal from the range counter is applied to the base of A5Q1 (A11). A5Q1 turns on, which turns on A5Q2. The output of A5Q2 is applied to range light one, and through A5R6 (A12) to the junction of A4R7 and A5CR3. The cathode of A5CR3 is connected to ground through A3Q2 (D17). -13 Vdc is applied through A5R8 to the junction of A5R7 and the gate of SCR A5Q3. As long as A5CR3 cathode is connected to ground, the negative potential across A5R8

keeps A5Q3 cut off. When an up error is applied to the comparators, A3Q2 turns off, removing the ground from the cathode of A5CR3. This causes +13 Vdc to be applied across A5R6 and A5R7 to the gate of A5Q3. A5Q3 turns on and remains on (conducting) until reset by the removal of voltage from its anode.

(d) The function of the miss logic (fig. 2-7) is to enable or inhibit the MISS and HIT lamps as determined by the presence or absence of aiming errors. The miss logic is comprised of an OR gate, a NAND gate, an AND gate, SCR memory circuits, a lockout circuit, a MISS lamp, and a HIT lamp.

(e) The outputs of the comparators are applied to the OR gate. The output of the OR gate and the output of the range counter clock are applied to the AND gate. When the AND gate is enabled, its output enables the SCR memory circuit. The output of the SCR memory circuit applies a ground to the MISS lamp and enables the NAND gate which removes ground from the HIT lamp. If no error signal is received by the comparators, ground connection to the HIT lamp remains intact. Upon completion of a firing run, relay K1 is reset, which applies power to the HIT and MISS lamps. Only the lamp to which a ground connection is made will illuminate. The NAND gate which inhibits the HIT lamp may also be enabled by the lockout circuit. The lockout circuit is enabled by activating RESET switch S3.

(f) The miss logic gates and other circuitry (fig. 2-5) are made up of discrete components. The operation of each of the error input circuits is identical; therefore, only the RIGHT error input circuit will be discussed.

(g) The RIGHT error input circuit is comprised of A6CR35 (C26), A6CR36, and A6CR37. The anode of A6CR35 is connected to the cathode of A6CR36 and through A5R105 (C28) to the gate of SCR A6Q25. A6CR35 is back biased by the output of the range counter clock (62). The cathode of A6CR37 is connected to ground through A3Q8 (C25) if no right error exists. If a right error signal is applied to the comparator, A3Q8 turns off, removing ground from the cathode of A6CR37. This allows the junction of A6CR37 and A6CR36 to rise toward +13 Vdc, causing A6Q25 to conduct.

(h) When A6Q25 turns on, it provides a ground to the MISS lamp (C29). A6Q25 also removes the breakdown voltage from zener diode A6VR1, which removes the drive from A6Q26. A6Q26 turns off, removing ground from the HIT lamp. A6Q26 may also be turned off by activating S3, which turns on SCR A7Q11 (D28). A7Q11 connects the cathode of A6VR1 to ground through A6CR48.

(i) The transmitter acquisition circuit is composed of an operational amplifier, a diode detector, an RC filter, a Darlington amplifier, and an indicator

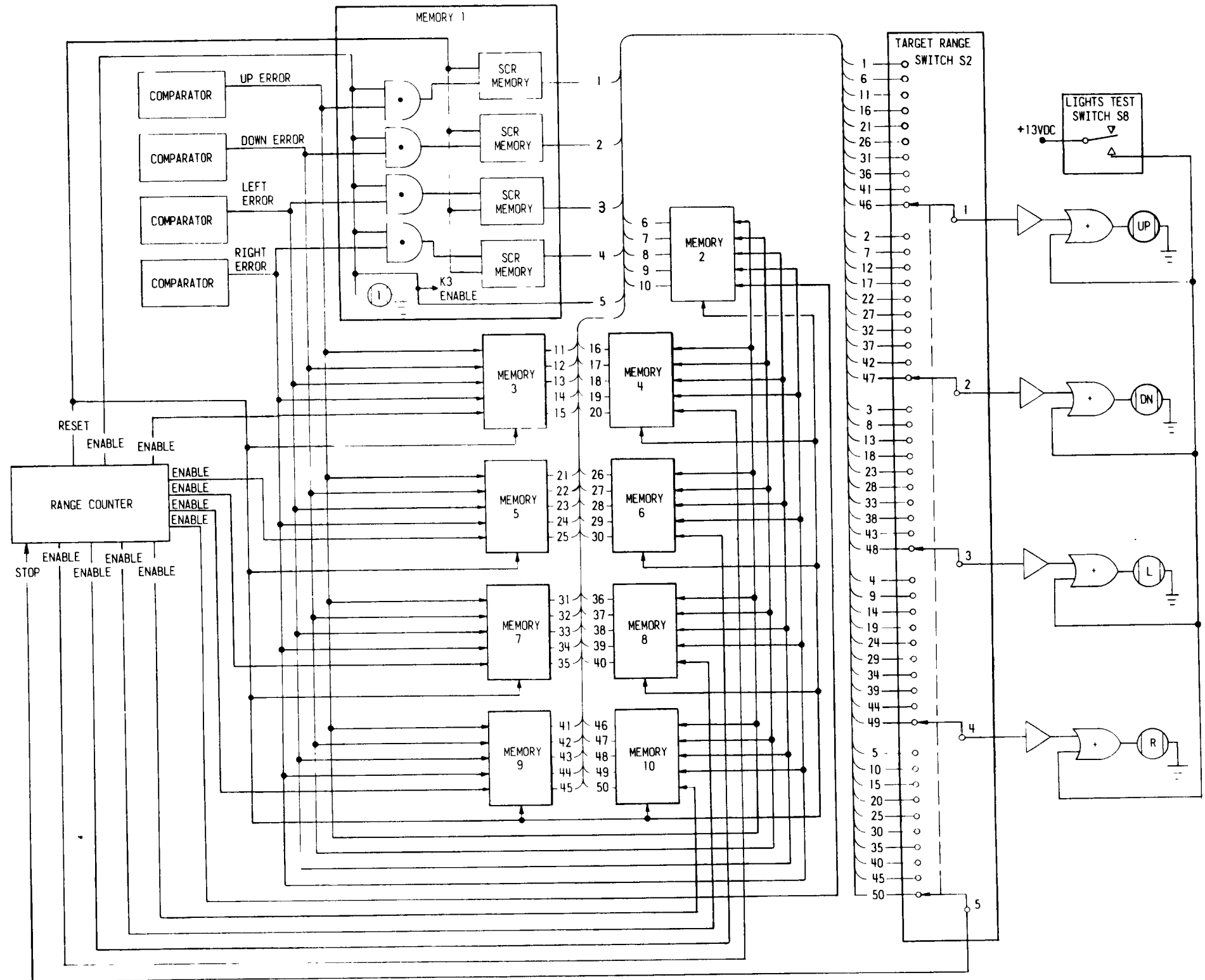

MS 161,523

Figure 2-6. Memory Circuits-logic diagram.



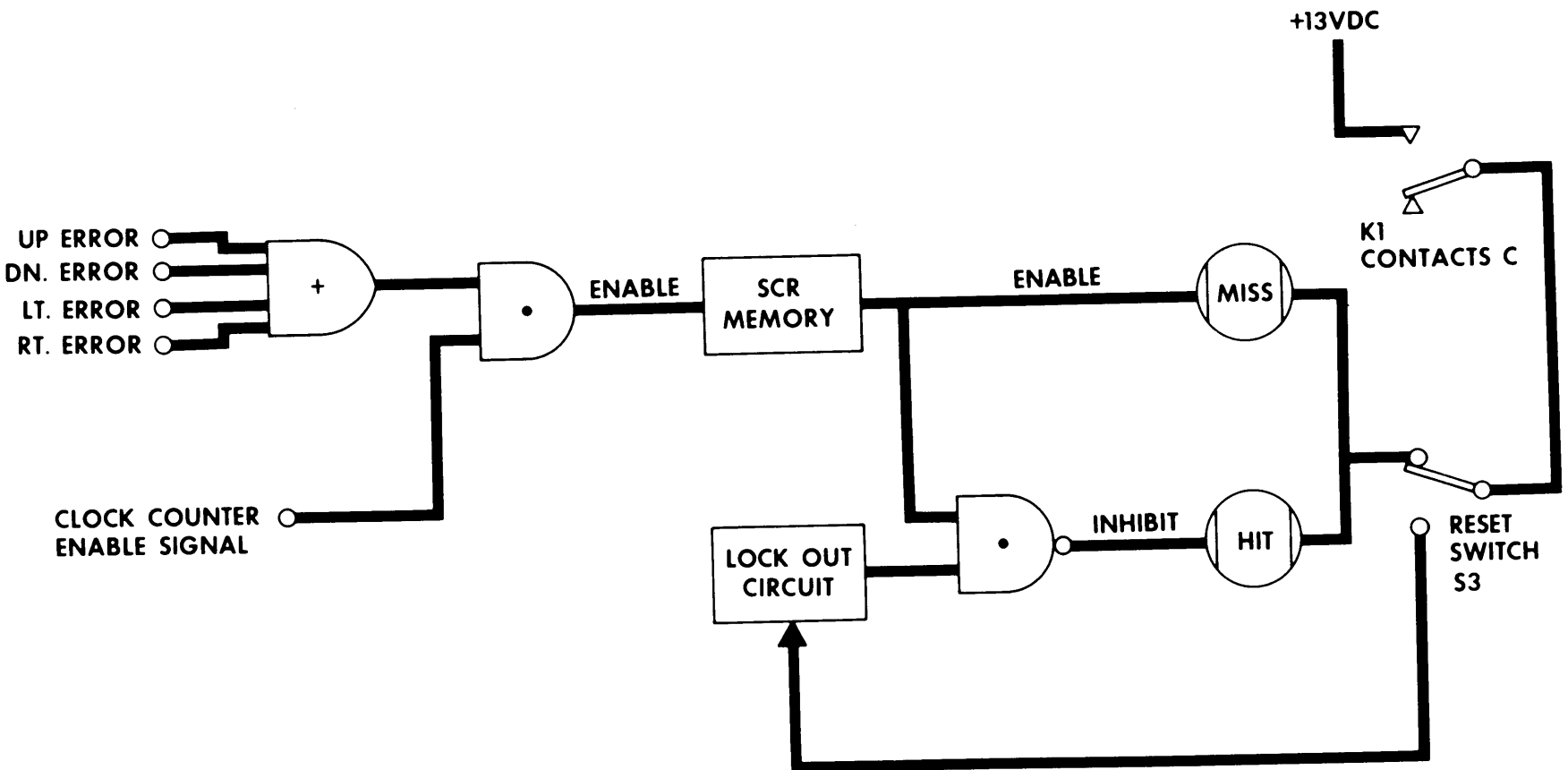

Figure 2-7. Miss Circuit- logic diagram.



lamp. The purpose of the transmitter acquisition circuit is to provide visual indication of an IR signal of sufficient amplitude to properly stimulate the tracker.

(j) The tracker sum signal is applied through A4R66 (614) to the noninverting input of operational amplifier A4AR1. A4AR1 output is coupled across A4C17 to A4CR57. The rectified output of A4CR57 is applied to the input of filter network A4R71 and A4C18. The output of this filter is applied to the input of a Darlington amplifier comprised of A4Q17 and A4Q18. When the Darlington amplifier conducts, a ground is applied to the IR XMTR lamp through A4Q18.

(k) The threshold of the Darlington amplifier is approximately 1.6 volts. A4AR1 has a gain factor of 8. Therefore, a sum signal amplitude of approximately 200 mv is required to turn on the IR XMTR lamp.

## 2-6. Electrical and Electronic Functions of the MTS Battery Charger/Regulator.

a. The battery charger/regulator (fig. 2-8) has both DC and AC input circuits. Operating voltages required are 105-130 Vac 50-400 Hz, 190-230 Vac 50-400 Hz, or 18-30 Vdc. The appropriate input circuit is selected by installing the proper power cable and correctly positioning the EXTERNAL POWER switch S1.

b. AC power is applied through S1 to autotransformer T1, where it is stepped down to 24 Vac and applied to a full-wave rectifier consisting of A6CR1, A6CR2, A6CR3, and A6CR4. The rectifier output is applied to the collector of voltage regulator A6QJ. A6Q1 duty cycle is controlled by the preregulator circuit. The output of A6Q1 is applied to the input of A6L1 and A6CR5. A6CR5 and A6C1 filter the output of A6Q1. The voltage at the output of A6L1 is maintained at +14 Vdc by the ratio of A6Q1 on-time to off-time (duty cycle). The output of A6L1 is applied to the input of the DC-to-DC converter and to the preregulator (fig. 2-9) at the junction of C1, R8, and zener diode CR1. C1 filters the preregulator input voltage. CR1 and R5 maintain the voltage at the emitter of Q4 at +9 Vdc. The input to the base of Q4 is taken from voltage divider R8, R10, and R14. When the input of C1 drops to less than +14 Vdc, Q4 is turned off, turning off Q5. Q5 collector goes positive, turning on Q3, Q2 and Q1, respectively. When Q1 turns on, its emitter goes positive, turning on A6Q1. A6Q1 conducts until the voltage at the output of A6L1 again rises to +14 Vdc, which turns on A2Q4.

c. DC power is applied through S1 directly to the collector of A6Q1. Thereafter, the battery charger/regulator circuits operate in exactly the same manner as when AC power is applied.

d. The DC-to-DC converter is comprised of a multivibrator consisting of A6Q2, A6Q3, and A6T2, and a full-wave rectifier consisting of A6CR6, A6CR7, A6CR8, and A6CR9. The output of the DC to DC converter is 60 Vdc. A6L1 output is applied to the emitters of A6Q2 and A6Q3. Oscillations of the multivibrator begin because of individual characteristic differences between Q2 and Q3. The square-wave output of Q2 and Q3 is stepped up to 60 volts by T2 and applied to the full-wave rectifier. This voltage is then applied to the emitter of current regulator Q4. The duty cycle of Q4 is controlled by the evaluator/charger circuit.

e. Input power to the evaluator/charger (A3) (fig. 2-10) is filtered by C3 and CR1 and applied to the input of L1. L1 output is applied through R16, R15, R10, R5, and CR4 to the negative side of the batteries. Input current to the batteries is maintained at 360 ma to 440 ma. Both temperature and current sensing circuits control the duty cycle of A6Q4, thereby controlling the input current.

f. A3Q2, thermostatic switch S9 and thermistor R3 are the active components in the temperature sensing circuit. At temperatures above 55°F, S9 closes, shorting R3. This connects A3R17 to ground, turning off Q2. At temperatures below 45°F, S9 opens, which permits A3R17 to drive the base of Q2.

g. R12 and Q4 comprise the current sensing circuit. R12 senses the voltage across the input voltage divider network. The wiper arm of R12 drives the base of Q4. When the voltage across R12 decreases to the point where the wiper arm potential is +4.8 Vdc, Q4 is turned off.

h. When Q4 and Q2 are turned off, Q1 is turned off. When Q1 turns off, Q3 turns on, turning on Q6. When Q6 turns on, its emitter goes positive, which turns on A6Q4. When either or both Q4 or Q2 are turned on, Q1 turns on, turning on Q3. This turns off Q6, which turns off A6Q4.

i. The +13 Vdc power supply (A4) (fig. 2-11) receives a +21 Vdc input from the evaluator/charger and the batteries, which is applied to the input of an over-voltage shutdown circuit and a Darlington amplifier. The +20 Vdc output of the Darlington amplifier is applied to an overcurrent shutdown circuit-and a driver circuit.

j. The driver circuit is comprised of Q9, Q5, A6Q5, and associated components. The output of the Darlington amplifier (Q1 and Q2) is applied to Q5 emitter and A6Q5 collector. The output from Q5 collector drives A6Q5 base. The output from Q5 emitter is applied to the power supply output filter. The output voltage is then applied to a differential amplifier consisting of Q6 and Q7, zener diode CR2, and associated components. The output of the differential amplifier drives the base of



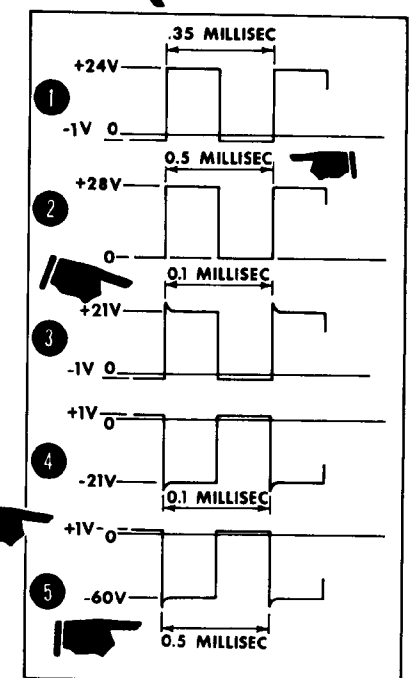
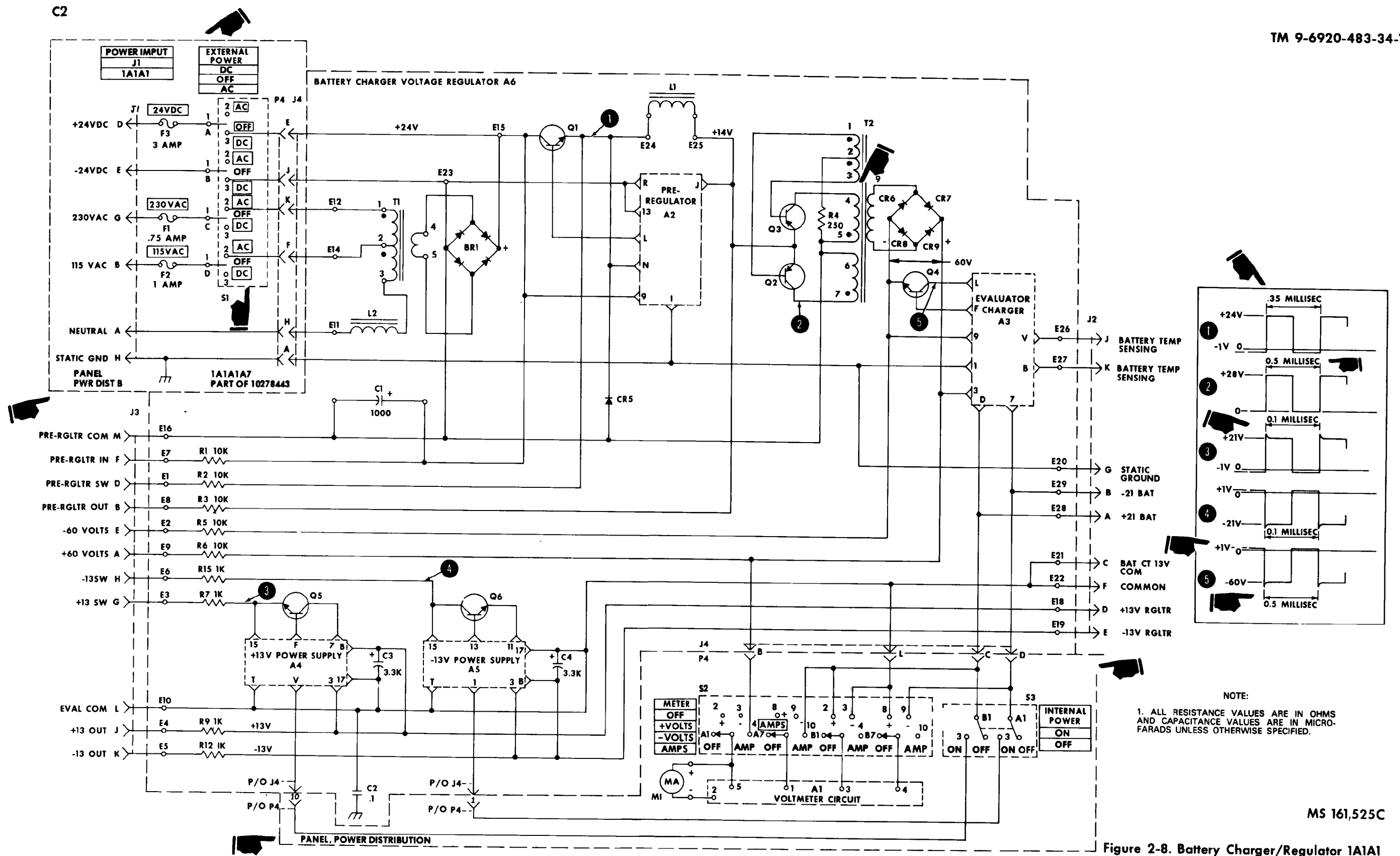

NOTE:  
1. ALL RESISTANCE VALUES ARE IN OHMS  
AND CAPACITANCE VALUES ARE IN MICRO-  
FARADS UNLESS OTHERWISE SPECIFIED.

MS 161,525C

Figure 2-8. Battery Charger/Regulator 1A1A1  
-schematic and parts placement. (sheet 1 of 2)



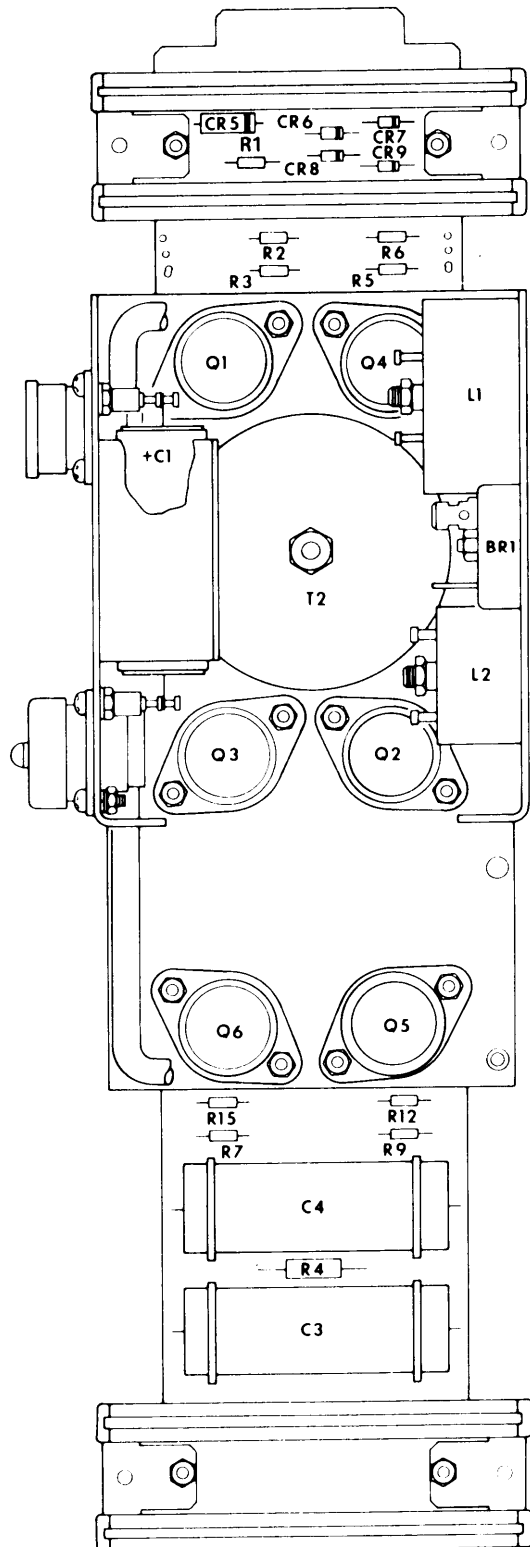

MS 161,526A

Figure 2-8 Battery Charger/Regulator (1A1A1) -schematic and parts placement. (sheet 2 of 2)



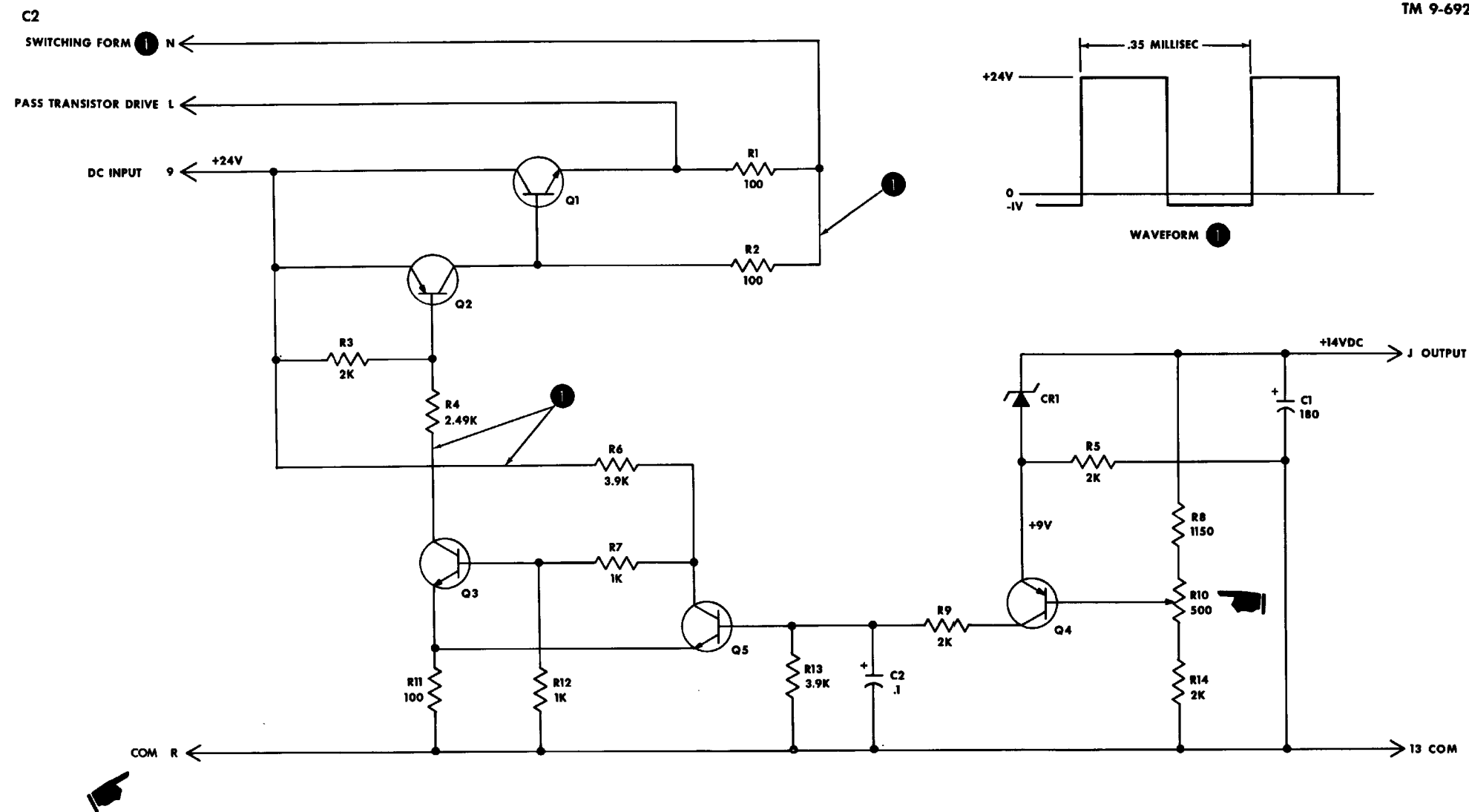

NOTE:  
1. ALL RESISTANCE VALUES ARE IN OHMS  
AND CAPACITANCE VALUES ARE IN MICRO-  
FARADS UNLESS OTHERWISE SPECIFIED.

MS 161,527B

Figure 2-9. Circuit card assembly 1A1A1A2  
-schematic and parts placement.  
(sheet 1 of 2)

2-53/(2-54 Blank)



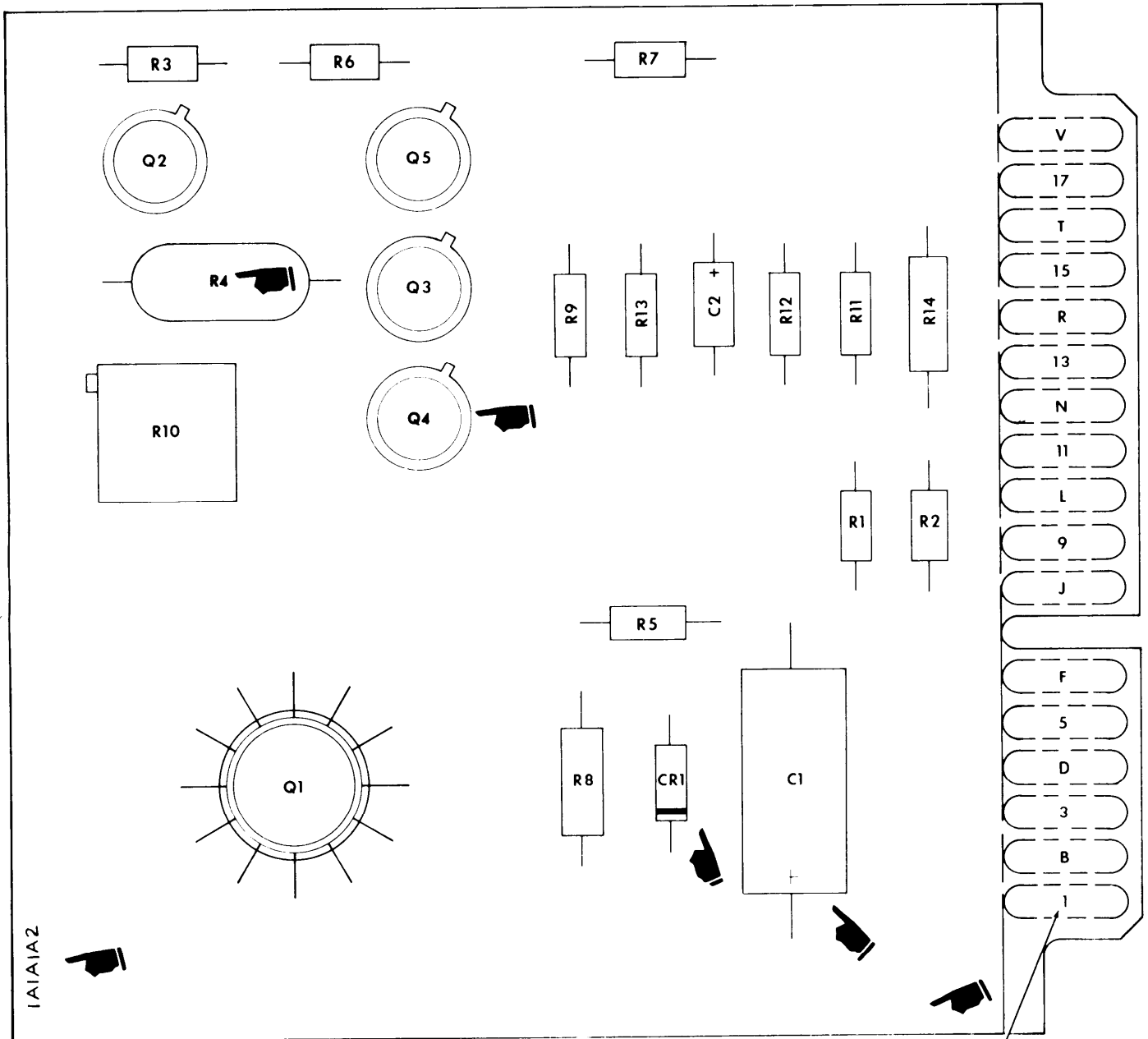

PIN DESIGNATIONS ARE FOR REF ONLY AND DO NOT APPEAR ON PART

MS 161,528B

Figure 2-9 Circuit card assembly 1A1A1A2, Pre-regulator -schematic and parts placement. (sheet 2 of 2)





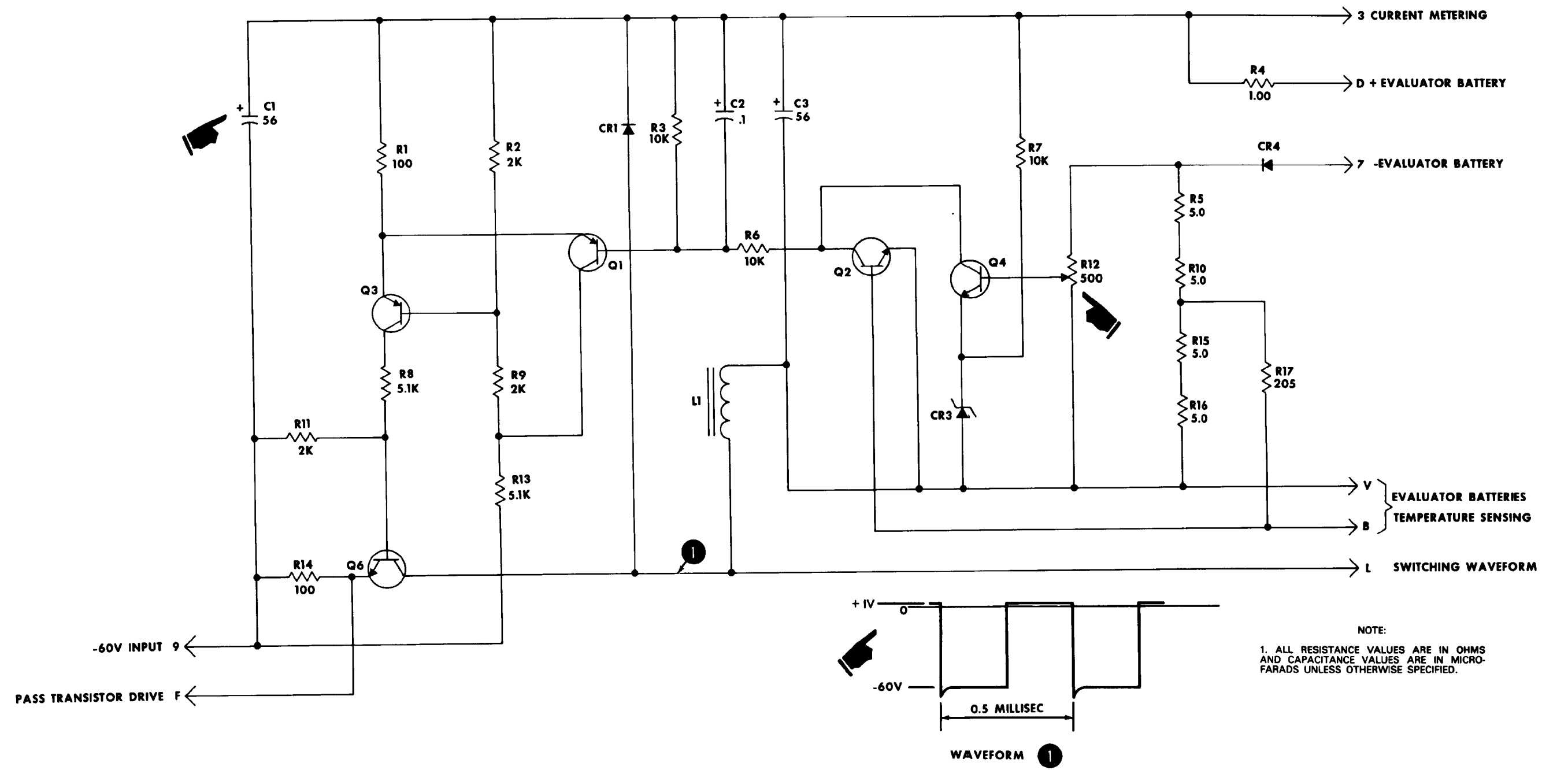

NOTE:  
1. ALL RESISTANCE VALUES ARE IN OHMS AND CAPACITANCE VALUES ARE IN MICRO-FARADS UNLESS OTHERWISE SPECIFIED.

MS 161,529C

Figure 2-10. Circuit card assembly 1A1A1A.3  
Evaluator/Charger-schematic and parts placement.  
(sheet 1 of 2)



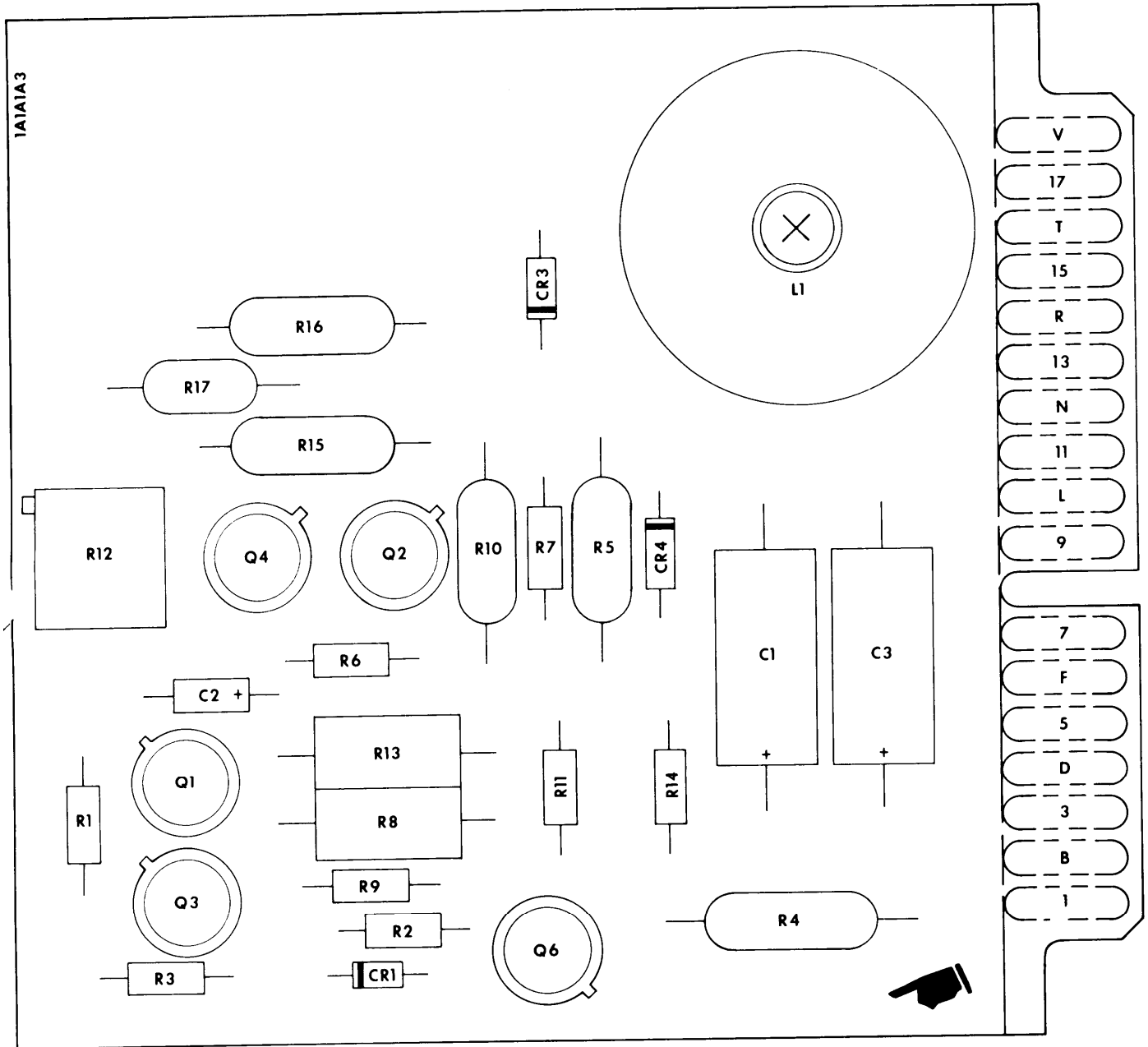

MS 161,530B

Figure 2-10. Circuit card assembly 1A1A1A3, Evaluator/Charger - schematic and parts placement. (sheet 2 of 2)



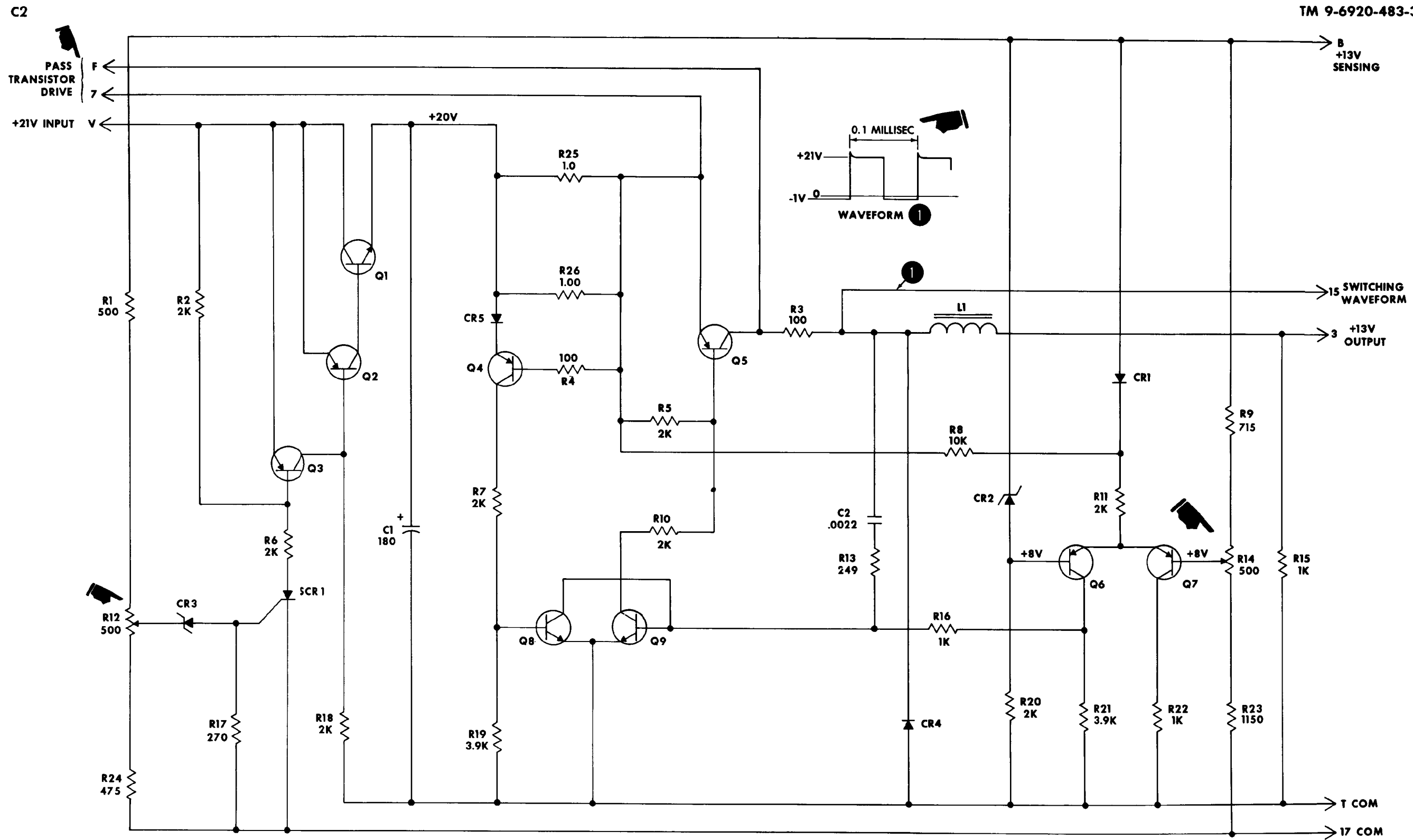

NOTE:  
 1. ALL RESISTANCE VALUES ARE IN OHMS  
 AND CAPACITANCE VALUES ARE IN MICRO-  
 FARADS UNLESS OTHERWISE SPECIFIED.

Figure 2-11. Circuit card assembly 1A1A1A4, +13 volt  
 Power Supply -schematic and parts placement.  
 (sheet 1 of 2)



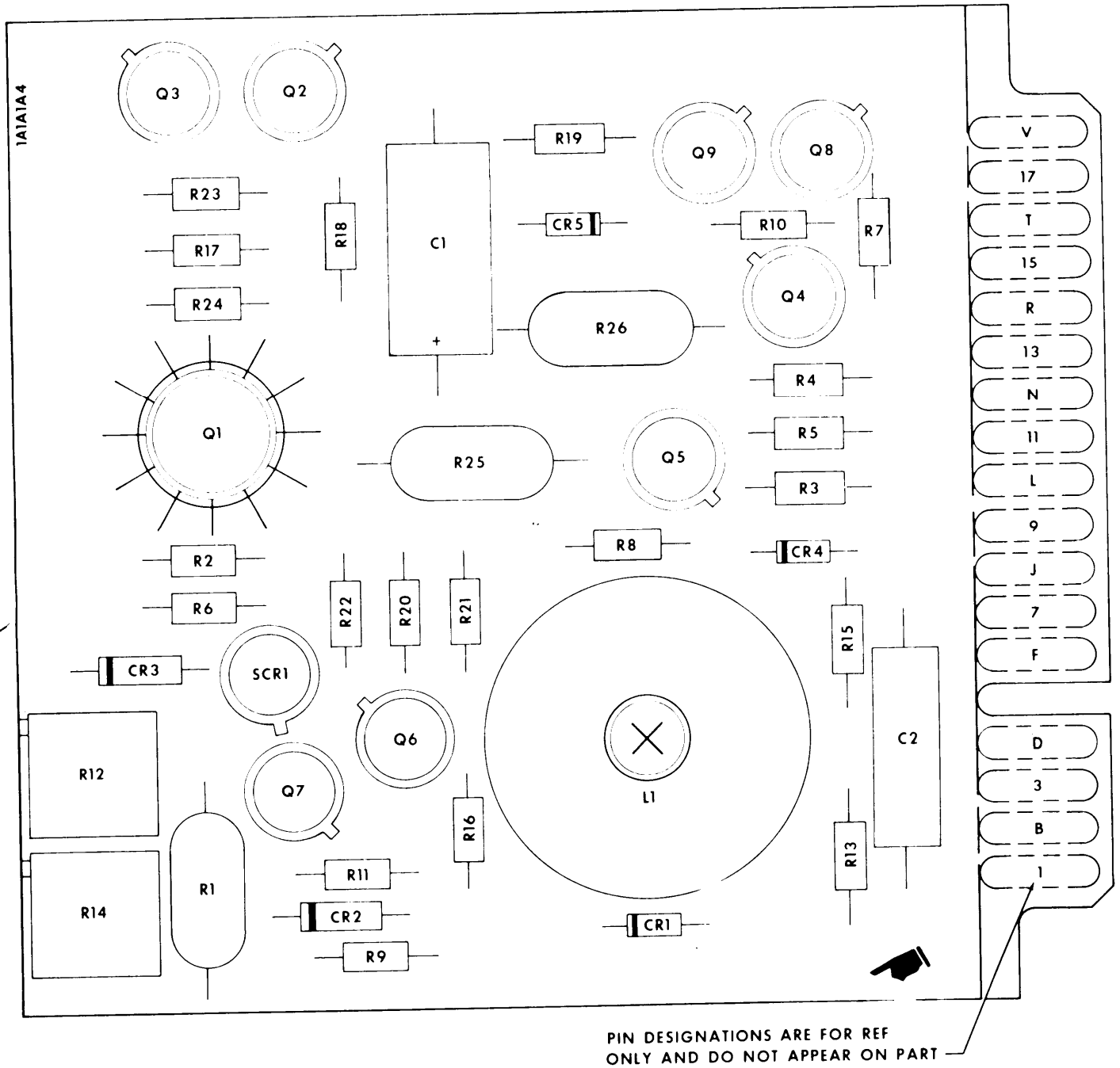

MS 161,532B

Figure 2-11 Circuit card assembly 1A1A1A4, +13 volt Power Supply -schematic and parts placement. (sheet 2 of 2)

Q9. When the power supply output voltage drops below +13 Vdc, CR2 conducts, causing current to flow through R20. This turns on Q6, which turns off Q7 and turns on Q9. The output of Q9 turns on Q5, which turns on A6Q5, causing power supply output voltage to rise to +13 Vdc. When the power supply output rises to +13 Vdc, the potential on the wiper arm of R14 turns on Q7, which turns off Q6 and Q9. The RC network consisting of C2 and R13 stabilizes the leading edge of Q5 output voltage. The output filter is comprised of CR4, A6C3, and L1.

k. The overvoltage shutdown circuit is comprised of Q3, CR3, SCR1, and associated components. Feedback from the power supply output is applied to R12. The wiper arm potential of R12 is applied to CR3. When this voltage exceeds +6.9 Vdc, CR3 conducts, turning on SCR1. SCR1 turns on Q3, which turns off the Darlington amplifier. This shuts down the +13 Vdc output.

l. The overcurrent shutdown circuit is comprised of Q4, Q8, and associated components. When current through R25 and R26 exceeds 3 amps, Q4 turns on, turning on Q8. The output of Q8 turns off Q9 which turns off the driver circuit. This shuts down the +13 Vdc output.

m. The -13 Vdc power supply circuit (A5) (fig. 2-12) theory of operation is the same as that of the +13 Vdc power supply with the exception of polarity differences. To achieve this polarity change, NPN transistors are substituted for PNP transistors and vice versa, as required.

n. The voltmeter circuit (A1) (fig. 2-13) and selector switch S2 provide inputs to meter M1 from the positive power supply, negative power supply, batteries, and evaluator/charger. The power supplies and batteries input circuit provides the capability of monitoring the charge state of the batteries. Current path is from the negative terminal through thermistor R17, R13, the meter movement, R10, R16, and R14 to the positive terminal. Overvoltage protection is provided by CR10 connected between the negative terminal and the junction of R14 and R16. A parallel path for current is through R17, R13, and R11. The evaluator/charger input circuit provides the capability to monitor charging current. The meter, in series with CURRENT ADJUST potentiometer R8, is connected through S2 across A3R4 in the evaluator/charger.

## 2-7. Electrical and Electronic Functions of the IR Transmitter.

a. The IR transmitter consists of a lamp assembly, a target board, a power supply/modulator, and vehicle adapters. The IR transmitter is powered directly from the target vehicle 24-volt battery. The lamp assembly consists of a gas lamp,



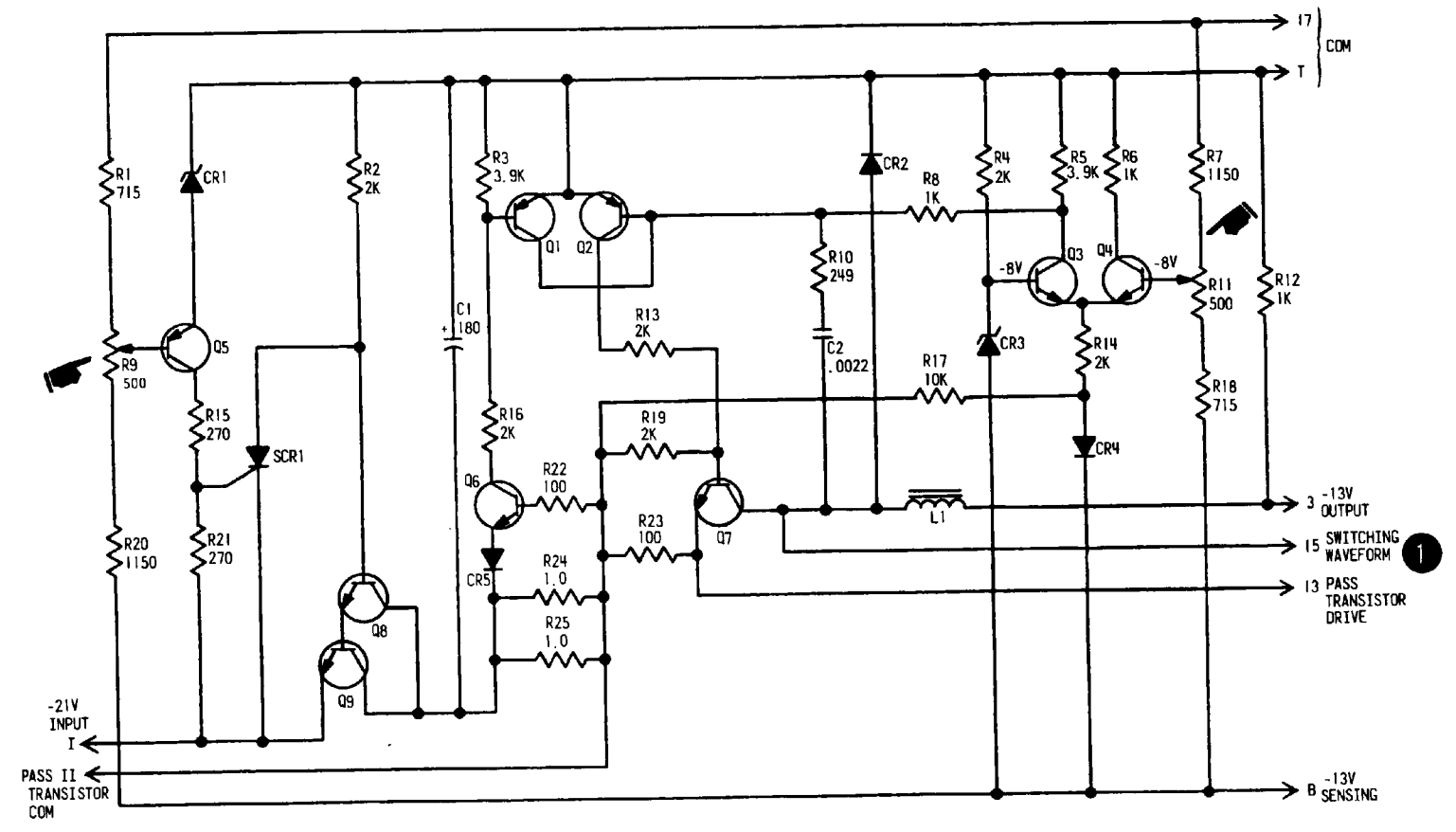

NOTE:  
 1. ALL RESISTANCE VALUES ARE IN OHMS  
 AND CAPACITANCE VALUES ARE IN MICRO-  
 FARADS UNLESS OTHERWISE SPECIFIED.

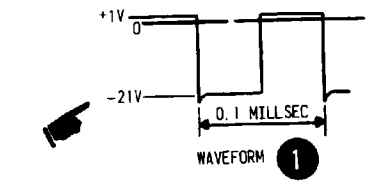

MS 161,533 C

Figure 2-12. Circuit card assembly 1A1A1A5,-13 volt Power  
 Supply -schematic and parts placement.  
 (sheet 1 of 2)

2-65/(2-66 Blank)



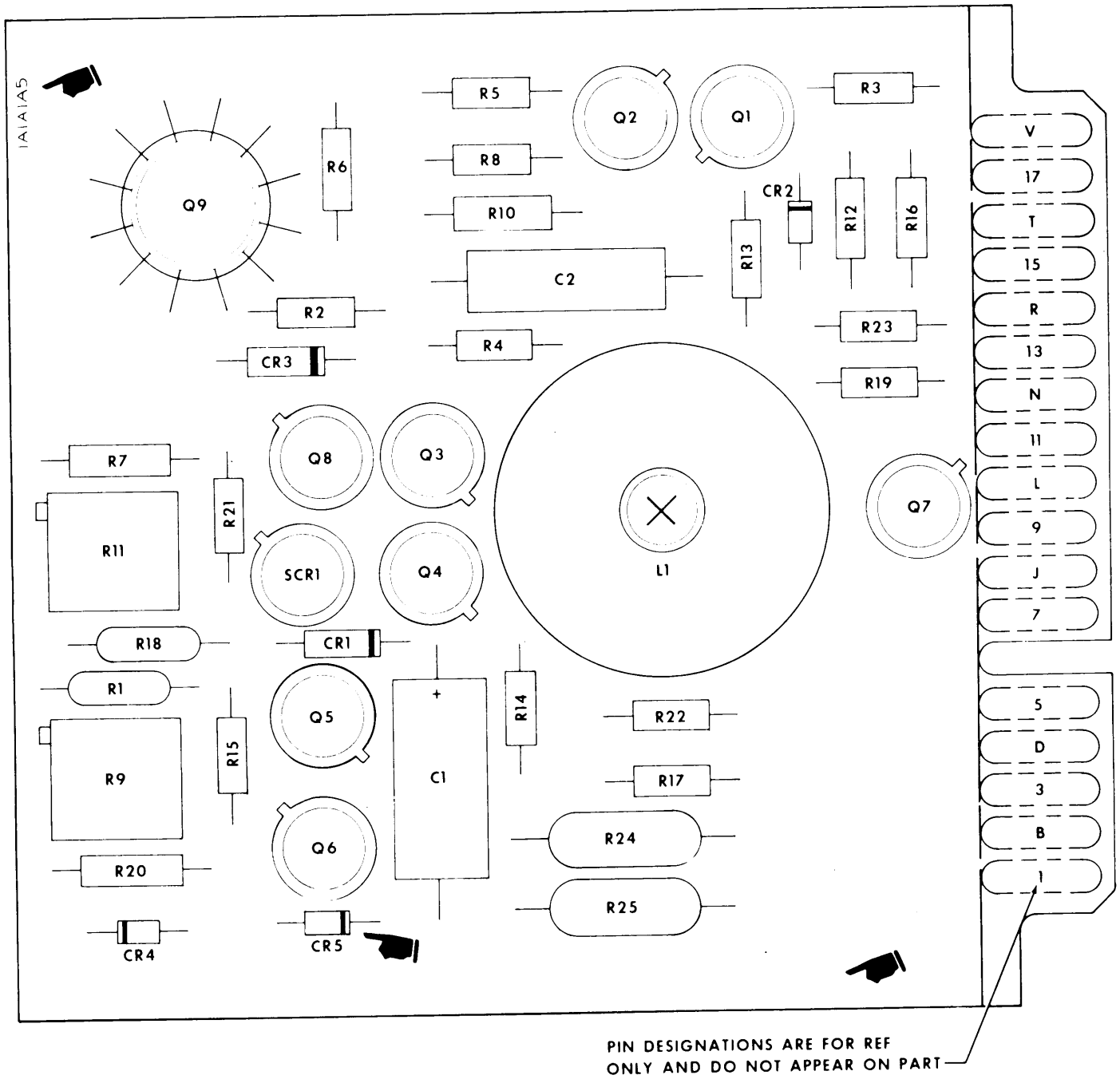

MS 161,534B

Figure 2-12 Circuit card assembly 1A1A1A5, -13 volt Power Supply -schematic and parts placement. (sheet 2 of 2)



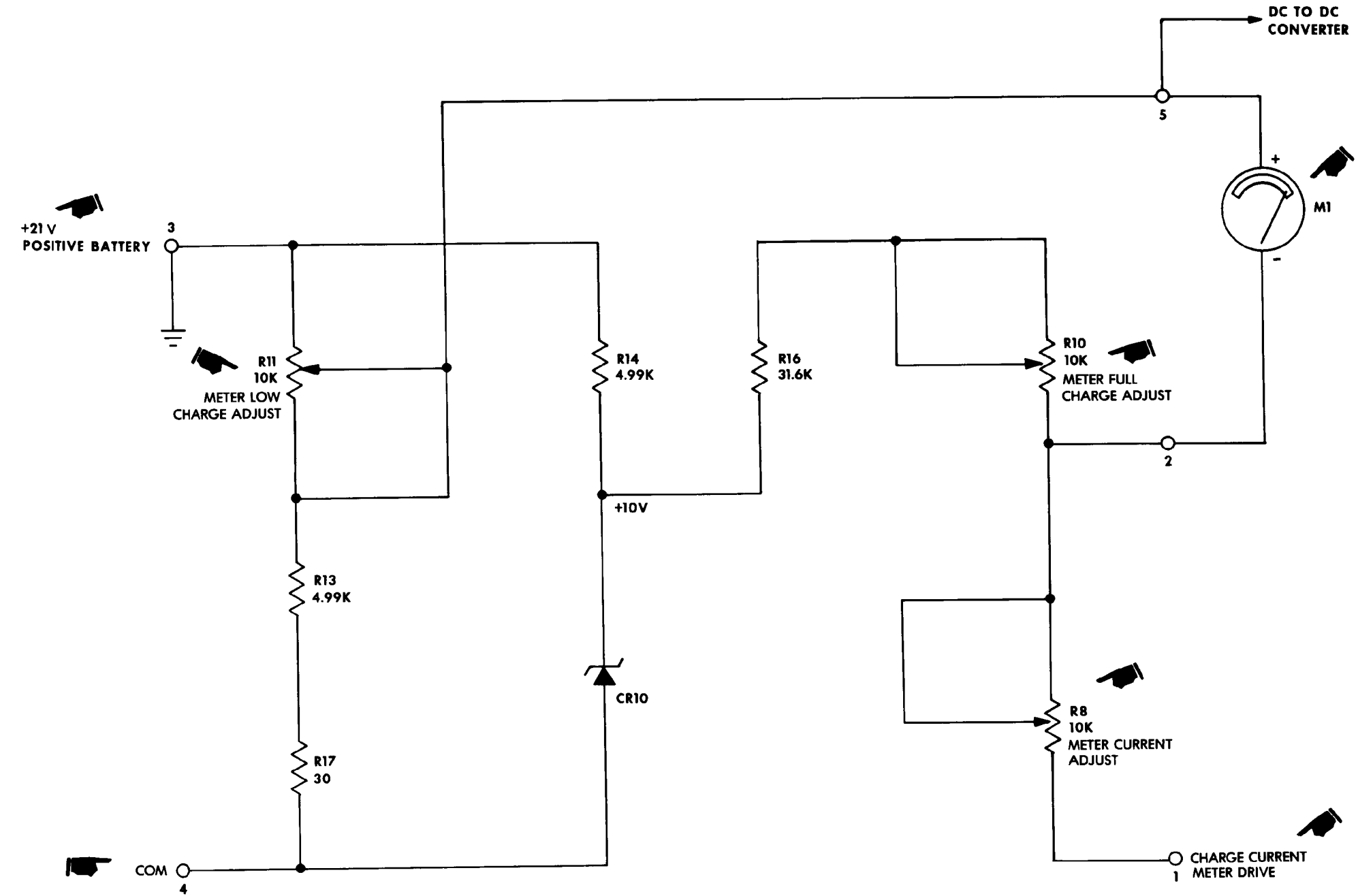

NOTE:  
 1. ALL RESISTANCE VALUES ARE IN OHMS  
 AND CAPACITANCE VALUES ARE IN MICRO-  
 FARADS UNLESS OTHERWISE SPECIFIED.

MS 161,535B

Figure 2-13. Voltmeter Circuit 1A1A7A1  
 -schematic diagram.



three lamp reflectors, a quartz window, a long wavelength pass filter, and a blower assembly with filtered intake and exhaust vents. A high voltage power supply for starting the lamp is housed within the lamp assembly.

b. The power supply/modulator (fig. 2-14) contains an auxiliary power supply, low voltage starting circuit, main current switch and drive circuit, idle current circuit, and power control PC card. The power supply/modulator is housed in a portable case. The front panel contains all controls and indicators for target source operation.

(1) Power supply. The auxiliary power supply develops an additional voltage of +6 Vdc for the lamp current, high and low starting voltages for turning on the lamp, and operating bus voltages for the electronics. The starting circuits are activated when the LAMP START switch is closed. The high voltage starting circuit applies a series of high voltage pulses to the lamp's starting electrode. The voltage to the lamp's anode is increased during the starting period by the low voltage starting circuit. Lamp power is returned through circuits that provide transistor switching at the nominal modulation rate and current regulation. The main current switch is driven on and off at a variable duty cycle. The modulation holdoff circuit prevents damage to the switching transistors and lamp during starting.

(2) Power control. Modulation is provided by PC card A1, which contains a freerunning oscillator and a flip-flop that produces the on-off drive output. The duty cycle is controlled by metering the lamp anode voltage and current on a per-cycle basis, in order to keep the average lamp power constant from cycle to cycle. An idle current circuit provides a second current path in parallel with the main current switch so that lamp current will never diminish to zero during the off cycle. The idle current minimum is raised during the starting period. After the starting period, the power control changes the mode by locking up a relay that disconnects the starting circuits and reduces the idle current minimum to a level suitable to sustain current flow during the off cycle.

c. The target source generates a modulated IR beam at a repetition rate of 5 kHz, using a 300-watt xenon lamp. The filtered beam extends +30 degrees in elevation and  $\pm 45$  degrees (minimum) in azimuth. The target source is offset from the center of a target board to compensate for the parallax error due to the tracker optical sight (optical/IR line-of-sight displacement). The power supply/modulator is contained in a portable case that contains a blower. The case is placed on a level surface of the vehicle so that it may be connected to the vehicle's 24-volt

supply and to the target source. The target source operator turns on the lamp by closing a circuit breaker and pressing a hooded LAMP START switch located on the front panel of the power supply/modulator. The target source will automatically start itself and maintain its operation until power is disconnected or the circuit breaker is opened. This leaves the operator completely free to perform other required functions. If he wishes to check target source operation, he need only check the ON indication of the LAMP MOD indicator on the front panel.

(1) Lamp starting. Voltage is supplied to one side of the xenon lamp, and the other (return) side is switched and current regulated. The voltage supplied is from the vehicle's battery with an additional +6 Vdc in series provided by the auxiliary power supply. During starting, this voltage is increased to approximately +150 Vdc while +15 kv pulses are applied to the lamp's starter electrode. When 24 Vdc 40A INPUT circuit breaker CB1 is closed, the auxiliary power supply applies +150 Vdc through deenergized start relay K1 to a paralleled array of electrolytic capacitors. The resultant charge yields a 6 amp current when the lamp is first fired. The high voltage starting circuit is a capacitive-discharge ignition circuit that develops 15 kv pulses at a rate of approximately 200 pps. Pressing LAMP START switch S1 applies both the +400 Vdc for the auto transformer that develops the high voltage pulses and the +24 Vdc that drives the freerunning oscillator in the circuit. When the mode of operation changes from start to sustain current, K1 becomes energized and disconnects the high and low voltage starting circuits.

(2) Idle current control (fig. 2-15). The idle current circuit, containing Q1 and Q2 connected as a Darlington pair, provides a second current path in parallel with the main switch so that lamp current will never diminish to zero during any part of the operating cycle. The state of K1 determines the minimal current that this circuit may draw, by adding or removing resistance. This provides current regulation of six amps during the start mode, and two amps during the sustain mode, thus assuring reliable operation of the lamp.

(3) Current modulation (fig. 2-15). The xenon lamp current is modulated at 5 kHz to simulate the modulation of the IR source in the tactical missile. The modulation is accomplished in the lamp power return line by means of paralleled main current switch transistors Q7 and Q8. The main switch is turned on (closed) by the positive cycles of the lamp drive on-off circuit amplifier (Q4 and Q5 driving Q3 and Q6) and turned off by the negative cycles. Power control card AI controls the main current switch drive on a per-cycle basis, so that the average lamp





power of any cycle is equal to that of the preceding one. In other words, the duty cycle is varied from cycle to cycle, with the average nominal duty cycle at 20 percent. The low duty cycle enhances lamp radiant intensity. The capability to vary the duty factor provides arc stability. The power control circuit achieves modulation control by metering the current in the lamp power return line and the lamp anode voltage. A shunt resistor at the main current switch applies the current sample to integrator AR1. The lamp anode voltage line applies the voltage to two-stage amplifier Q7 and Q8, which feeds an inversely proportional reference voltage into differential comparator AR2. The product of the lamp current and voltage is approximated by summation, and compared to a constant in AR2. When the power product during any cycle reaches this constant value, power is removed. The lamp drive on-off circuit that determines the modulation in the lamp current is controlled by flip-flop Q5 and Q10 through emitter follower Q6. The flip-flop is set each cycle by unijunction transistor oscillator Q2. R4 allows adjustment to 5 kHz. The exact time in each cycle that the flip-flop changes state to turn off the main switch is governed by a reset command generated by AR2 when coincidence between the sensed power in the on cycle and the constant reference occurs. In this manner, modulation with a steady frequency but variable duty cycle is achieved. The duty cycle circuit consists of Q12 and Q13 and contains R37, the duty cycle calibration resistor. This circuit drives OPERATING RANGE meter M3, located on the front panel.

(4) Current mode control . Card A1 also changes the operating mode from start to sustain, and automatically returns to the start mode if the lamp becomes extinguished accidentally prior to opening the circuit breaker. This control is achieved by relay control circuit switch Q15 (driven by Q14), which employs a negative peak detector that monitors the charge level at integrator AR1. After a few cycles of operation, the charge level is sufficient to cause the switch to close and energize K1. Energizing the relay disables the high and low voltage starting circuits, disconnects R3 in the idle current circuit to reduce the minimum sustaining current from six to two amps, and disables LAMP MOD indicator DSI. If the lamp goes out, decay of the charge level quickly causes Q15 to open, deenergizing K1 and returning to the start current mode.

(5) Xenon short arc lamp. Lamp DSI is a standard 300-watt, three-electrode, xenon lamp 4-3/4 inches long with a maximum bulb diameter of 0.765 inch. It is mounted in the vertical position [anode (+) at the top] with conical reflectors symmetrically mounted above and below the arc to intercept all rear-directed rays between 30 and 60 degrees from the horizontal and reflect them to within 30 degrees

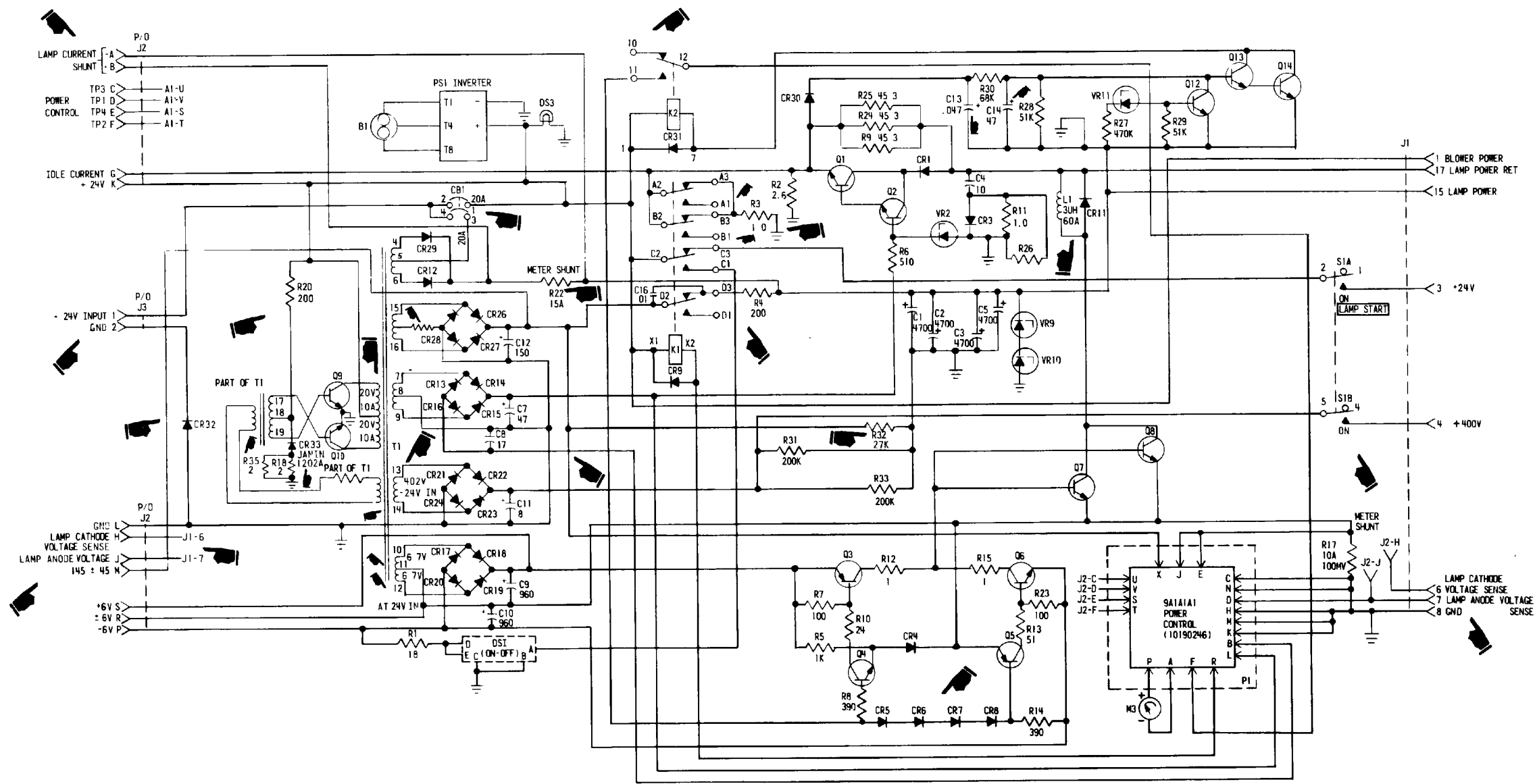

MS 161,537 A

Figure 2-15. IR Transmitter PS/M- (10225677) schematic diagram.

2-75/(2-76 Blank)



of horizontal. The azimuth field of view is  $\pm 45$  degrees. A spherical reflector behind the arc enhances the radiant intensity. A curved quartz window covers the forward portion of the lamp assembly and protects the IR filter, which has characteristics similar to those of the IR filter used in the DRAGON missile IR source. Blower BI, operated from the +24 Vdc through inverter PS2, is mounted beneath the bottom reflector and provides a continuous airstream to cool the lamp. Air is forced through an opening in the lower reflector past the lamp, and exits through an opening in the top reflector.

d. The power supply section consists of an auxiliary power supply (converting +24 Vdc from the vehicle's supply) that provides five individual voltage sources for the target set, a main switch circuit, a drive circuit for the switch, an idle current circuit for the lamp, and a low voltage starting circuit for the lamp. The power supply also contains a power control circuit, which is described in para. 2-7e following. The high voltage power supply is in the target source.

(1) Auxiliary power supply. This circuit (fig. 2-15) is a DC to DC converter which consists of Q9 and Q10 driving saturable transformer T1 in a multivibrator mode. Power is applied to the transformer through CB1, which connects +24 Vdc to the primary of the transformer and flip flop Q9 and Q10. Full wave bridge rectification with capacitor input filters provides five secondary outputs. CR13-CR16 supplies +15 Vdc to operate the power control circuit. CR25 - CR28 supplies +150 Vdc to charge up the starting capacitors. CR17 - CR20 supplies  $\pm 6$  Vdc for the drive circuit. CR21 - CR24 supplies +400 Vdc for the high voltage starting circuit. CR12 and CR29 supply +6 Vdc at 15 amps as an additive voltage to augment the battery assembly voltage for the lamp supply. The externally supplied +24 Vdc from CB1, when switched through K1 during operational on-time (K1 energized), also supplies the LAMP MOD indicator. The +24 Vdc from CB1 also drives blowers in the target source and power supply/modulator, and illuminates panel light DS3. The lamp current is monitored across R22 for application through pins J2-A and J2-B of the 24 Vdc 4A MAX AUX PWR connector as a safety provision (beacon, horn, etc.) to warn that the lamp is on. Pins J2-D, F, C, and E provide access to test points one through four, respectively, in the power control card.

(2) Main current switch (fig. 2-15). Paralleled switching transistors Q7 and Q8 are located in the lamp power return circuit. They are capable of switching peak currents of 60 amps. L1 and CR11 in the collector circuit reduce the strain imposed on the transistors during turn-on, and maintain a reduced voltage across them until turn-off is completed. R17 provides metering of the modulated lamp

current by the control circuit.

(3) Drive circuit (fig. 2-15). The main switch is driven by two complimentary double-drive stages; one for turn-on, the other for turn-off. The turn-on stage, consisting of Q4 and Q3, is connected through R12 to the main switch transistor bases. The turn-on stage is powered by the +6 Vdc supply from output filter capacitor C9. The turn-off stage, consisting of Q5 and Q6, is connected through R15 to the main switch transistor bases. This turn-off stage is powered by the -6 Vdc supply from output filter capacitor C10. The control input for both driver pairs is provided by a flip-flop in the power control circuit. This flip-flop input is applied through P1-F, energized relay K2, and R8 to the base of Q4, and CR5 - CR8, to the base of Q5. When the flip-flop output goes low, the turn-on drivers are actuated to close the switch. When the output goes high, the turn-off drivers open the switch.

(4) Modulation holdoff circuit (fig. 2-15). This circuit prevents the modulation of the lamp excitation until the turn-on cycle has been completed. This provides for more reliable operation because of the following reasons:

(a) Prevents the high voltage turn-on spikes from damaging the modulation switching transistors.

(b) Prevents excessive current flow through the lamp, which could be caused by switching the low side of the lamp to ground with high voltage applied.

(c) Provides for more reliable starting, by preventing the modulation signal from interfering with the DC starting mode. The power control modulation is applied from Pi-F to the main switch drivers via contacts eleven and twelve of K2 when its coil is grounded by switch Q14, which is driven by current amplifier Q13. However, Q13 is prevented from conducting during the starting period by the conduction of Q12, which shorts the base of Q13 to ground. The base of Q12 is connected to a voltage divider that consists of R27, R29 and zener diode VR11. The voltage divider is connected between the lamp power line and ground, with the polarity of VR11 such that its bias voltage is part of the voltage drop to the base of Q12. When lamp start relay K1 is energized (due to integrator action in the power control circuit after lamp current begins to flow), the lamp power line is switched from the +150 Vdc to the +30 Vdc section of the transformer and the capacitors in the low voltage starting circuit begin discharging to the lower voltage. The drop across R29 declines to a value that cuts off Q12. This permits Q13 and Q14 to conduct and energize K2. The bias voltage for the base of Q13 is obtained from a filter-integrator consisting of R30, R28, C13, and C14. The input to this circuit

is applied through CR30 from the idle current circuit, Q1 and Q2. As long as the sustain current mode of operation is maintained, the current flow into the filter-integrator is sufficient to provide bias voltage to Q13 to keep it conducting. However, if the lamp goes out, K1 deenergizes and returns the idle current circuit to the starting mode. The current drops and Q13 and Q14 are cut off, deenergizing K2 in order to permit restarting.

(5) Idle current circuit (fig. 2-15). This circuit provides a second current path in parallel with the main switch to insure that lamp current will never diminish to zero, and thus extinguish the target source during any part of the operating cycle. The circuit consists of Q1 and Q2 connected as a Darlington pair. They are connected to the lamp power return line through CR1, which prevents reverse collector current from flowing to the main switch when it is turned on. The circuit is connected through R6 to the plus side of bridge rectifier CR13 - CR16, which provides a +15 Vdc output. Current regulation is provided by driving the base of Q2 from the constant voltage established by CR 13 - CR16 and zener diode VR2. The current is established by the constant voltage drop across the variable resistance from the emitter of Q1 to ground. In the sustain current mode, R2 is the effective resistance at the emitter output. It provides a constant current of about 2 amps. However, in the start current mode (K1 deenergized), R3 is paralleled with R2. The lower resultant resistance provides a current of about 6 amps. This increased current provides more reliable starting of the lamp, while the subsequent two-amp current insures that reliable lamp operation will be sustained, unless the voltage across the circuit exceeds +32 Vdc. The 15 ohm resistance (R9, R24, and R25) paralleled across the collector circuit decreases the current the transistors must handle and damps out inductive spikes.

(6) Low voltage starting circuit (fig. 2-15). During the starting period, +150 Vdc is applied from C12 through contacts D2 and D3 of K1 and R4 to C1, C2, C3, and C5. These capacitors are charged when CB1 is closed. When the lamp is first fired (that is, when LAMP START switch S1 is closed and current flow in the lamp commences), this high voltage is discharged from the capacitors at a 6-amp rate until the voltage declines to the normal +30 Vdc supply obtained through R22 from CR12 and CR29, which are back-biased while the voltage on the capacitors exceeds the normal lamp supply voltage. When the lamp is operating normally, the control circuit energizes K1. This disconnects the capacitors from the +150 Vdc supply. VR9 and VR10, in series across the capacitors, provide voltage regulation when the normal (+24 Vdc external and +6 Vdc additive) supply becomes operative to sustain

lamp operation.

(7) High voltage starting circuit. This circuit (fig. 2-16) is a high voltage generator powered by +400 Vdc and +24 Vdc from the auxiliary power supply through deenergized relay K1 (fig. 2-15). The generator is a capacitive-discharge ignition circuit that begins pulsing when the LAMP START switch S1 is closed, applying +400 Vdc through connector J1-4 to the high voltage power supply. Autotransformer T1 (fig. 2-16) receives a +400 Vdc step signal from C1 every time SCR1 fires. Autotransformer action generates a 15 kv pulse for each input step. Ringing action, developed when C1 discharges through the primary of T1, turns off T1. SCR1 fires 20 times a second, since it is driven through C2 by unijunction transistor Q1, which free runs at a rate of 20 pps. Q1 is supplied with +24 Vdc through switch S1 and J1-3, until relay K1 is energized. The high voltage from T1 is applied through terminal E1 to the starter electrode of lamp DS1 (fig. 2-17), to light the lamp initially by the series of 15 kv ignition pulses.

(8) Lamp current starting and sustaining. Lamp DS1 (fig. 2-17) is a three-electrode lamp rated at 300 watts. Voltage is supplied to one side of the lamp, and the other side (return side) is switched and current regulated. The voltage supply (fig. 2-15) is the battery voltage (+24 Vdc applied through CB1 to secondary winding center tap terminal five of T1) with an additional +6 Vdc developed by the auxiliary power supply. During starting, this voltage is increased initially to +100 Vdc by the use of an array of capacitors [subparagraph 2-7d(7)]. once the gas has ionized, current will begin to flow in the lamp, because a difference in potential exists between its anode and cathode. To insure the flow, the idle current circuit provides a temporary surge of four joules to stabilize the current. When the lamp begins operation, the current sensed by the power control circuit through Pi-E and Pi-C (lamp shunt and return across R17), causes the power control circuit to energize K1 and disable the starting voltage. The modulation holdoff circuit extends the starting mode to approximately five seconds by blocking the modulation applied from the power control circuit to the main switch drivers.

e. The power control circuit (fig. 2-18) monitors lamp power on a per-cycle basis and keeps the average lamp power of any cycle equal to the lamp power of the preceding cycle. The product of the lamp current and voltage is approximated by summing the current and voltage and comparing it to a constant. When the sum of current and voltage during any cycle reaches the constant value, power is removed from the lamp by means of the main switch and driver circuits.

(1) Lamp current integration. The lamp shunt and return lines at J1-E and



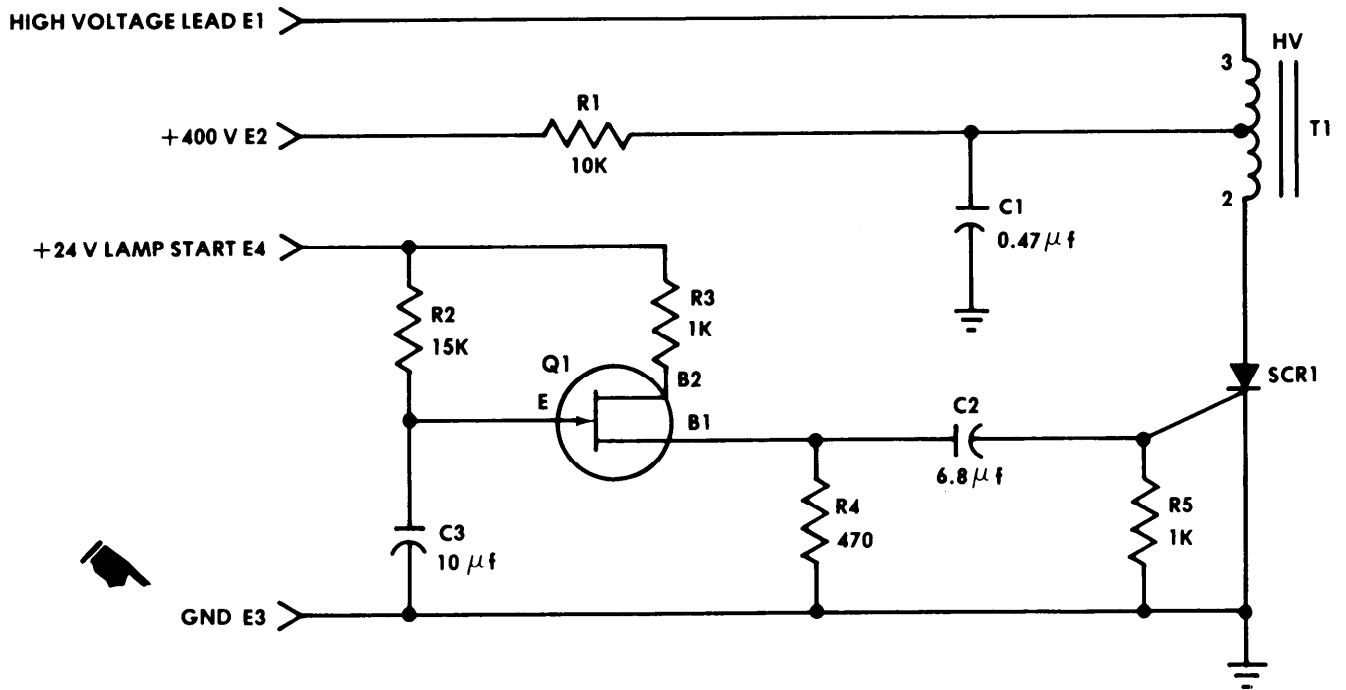

MS 161,538A

Figure 2-16. Lamp Assembly HVPS- schematic diagram.

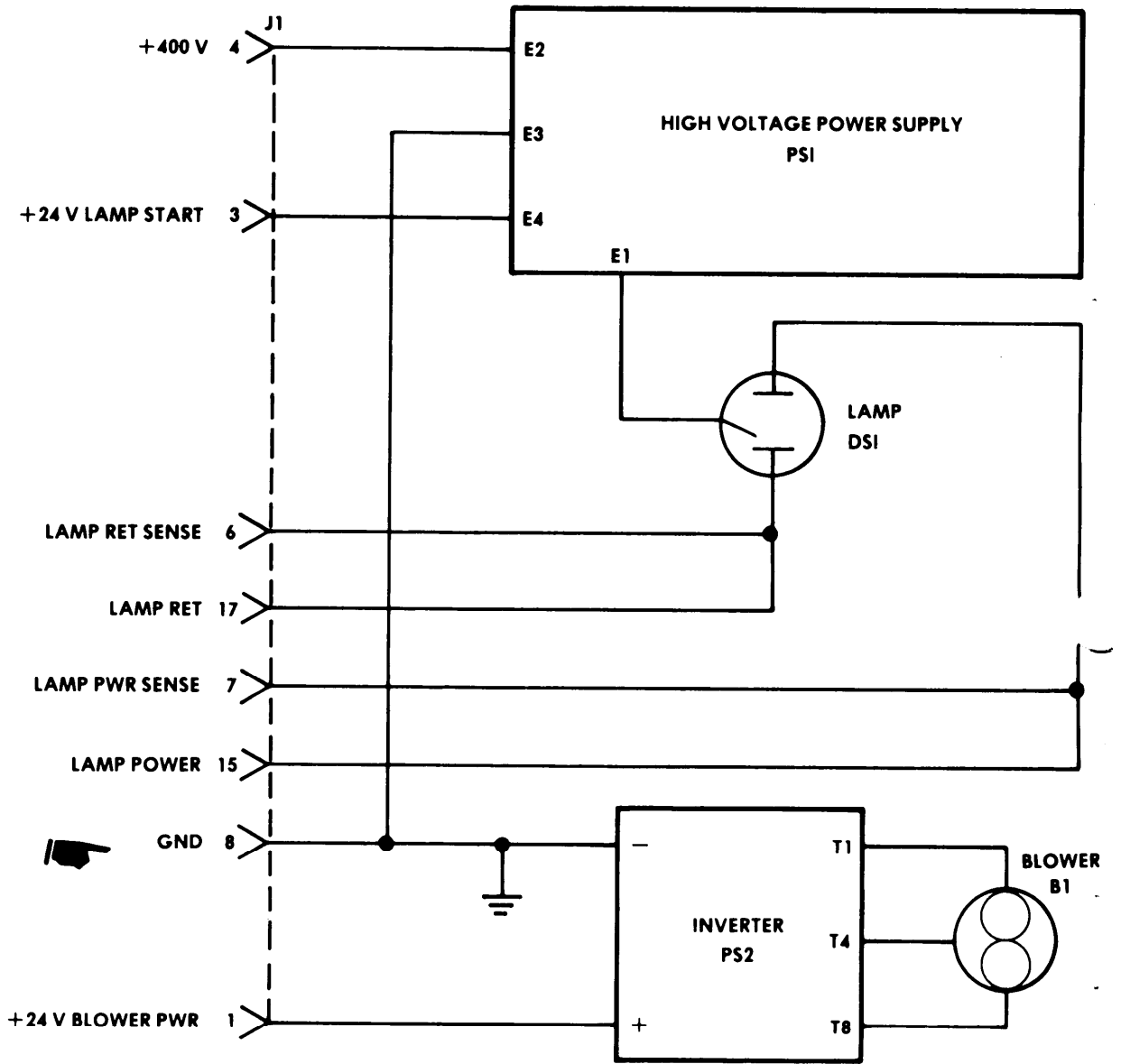

MS 161,539A

Figure 2-17. Lamp Assembly-(10225678) schematic diagram.

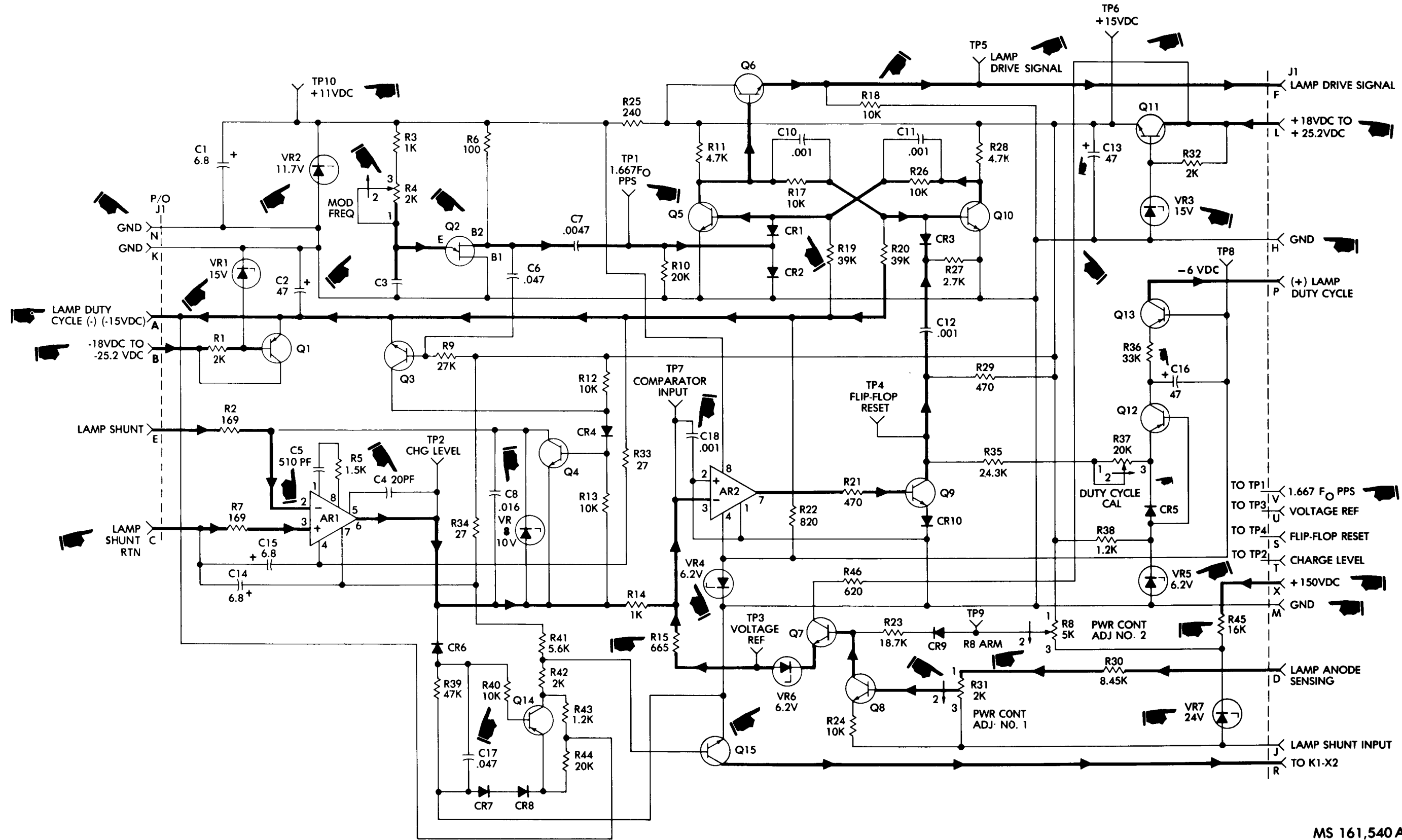

MS 161,540 A  
 Figure 2-18. IR Transmitter Power Control card-11500196



J1-C are connected across R17 in the emitter path of the main switch circuit in the power supply (fig. 2-15). This resistor is the source for metering the modulated lamp current. The sampled current signal is applied through R2 to integrator AR1 (fig. 2-18), an operational amplifier circuit. The integrator output is applied through R14 to differential comparator AR2 for comparison with the lamp anode voltage.

(2) Differential comparison. The integrator output is compared to the lamp anode voltage by summing it with a voltage inversely proportional to the lamp voltage. The lamp anode and cathode voltages are applied through J1-D and J1-J across R30 and R31 to provide sampling of the voltage across the lamp. A portion of the voltage, derived from the wiper arm of power control adjustment R31, is amplified by Q8 and Q7 to provide the reference voltage through R15 to differential comparator AR2. This injects the required constant into the computation. When coincidence is reached, a logic turn-off command is obtained from AR2 and applied to Q9.

(3) Main switch on-off driving. The main switch transistors are driven by two complimentary pairs of transistor drivers. Conduction of the drivers is controlled by the output of a flip-flop containing Q5 and Q10. The turn-off command developed by AR2 and amplified by Q9 is the flip-flop reset signal, which is coupled through C12 and R27 to the emitter of Q10. When the flip-flop changes state, the positive cycle is coupled through emitter follower Q6, J1-F, and modulation holdoff relay K2 to the drivers in the main switch drive circuit, thus opening the switch. After a period of time, the flip-flop is set by unijunction transistor Q2, which free-runs at 5 kHz. The main switch drivers are sequenced so that turn-on occurs during positive cycles and turn-off during negative cycles.

(4) Modulation duty cycle. The control circuit varies the modulation duty cycle to maintain the lamp power at a constant level; that is, it keeps the average lamp power of any cycle equal to the lamp power of the preceding cycle despite variations in the switch on-off timing. The modulator is designed to operate nominally at a 20 percent duty cycle. The capability to automatically vary the duty cycle prevents the extinction of the lamp arc by an external interference. If some lengthening of the arc should occur (by an acoustical resonance, for example the duty cycle will increase, thus tending to stabilize the arc. An additional advantage in operating at a nominal duty cycle of less than 50 percent is that lamp radiant intensity is enhanced. Oscillator operation is provided by unijunction transistor Q2, C1, C3, R3, and R4. The latter resistor is variable, to enable preset adjustment of the oscillator to 5 kHz. The oscillator output is applied

through C7 to the flip-flop, and through C6 to the base of Q3, which drives Q4 through CR4 in order to reset AR1 for the next cycle. The basic adjustment for the 20 percent duty cycle is provided by a circuit containing Q12 and Q13. The flip-flop reset signal is applied through R35 and R37 to the emitter of Q12, which is normally at cutoff. The latter resistor is variable, to enable adjustment and calibration of the duty cycle. The AR2 output, during the on portion of the duty cycle, charges C16 at the base of Q13. The capacitor discharges during the off portion of the duty cycle when Q12 conducts. The cycling establishes an average current proportional to the duty cycle. The lamp cycle output at J1-P and its return at J1-A are connected across OPERATING RANGE meter M3 to indicate the duty cycle. R22 provides base bias for Q13.

(5) Starting relay control. K1, in the power supply (fig. 2-15), provides for increased idle current, relays power to the low voltage starting circuit, and relays power to the high voltage starting circuits during a short initial starting period, which begins immediately after the operator presses the LAMP START switch. The relay makes those connections when it is deenergized, and breaks them when it is energized. The relay is energized when stable lamp current is achieved, and held energized by the control circuit as long as proper lamp current and duty cycle is sensed. Closing CB1 applies +24 Vdc to the coil of K1. Terminal X2 of K1 is connected through J1-R to Q15, which is initially open due to the low voltage applied to its base from the voltage divider composed of R34, R41, R42, and R43. At this time, Q14, which is the driver for Q15, is also cut off, since its base is grounded through R39. When the LAMP START switch is pressed, lamp current flow is detected and the operation of integrator AR1 begins. When the charge level declines sufficiently at C4, negative-going peak detector CR6 and C17 lower the base voltage of Q14 sufficiently to switch it on. This removes R43 and R44 which causes the voltage at the base of Q15 to rise above cutoff, causing Q15 to conduct and K1 to energize. This disconnects power from the high and low voltage starting circuits and lowers the idle current. K1-C1 and C2 apply power to LAMP MOD indicator DS1.

(6) Voltage regulation. Voltages are supplied to the power control circuit (fig. 2-18) from the auxiliary power supply (fig. 2-15). The voltages are +150 Vdc at J1-X, +18 to +25.2 Vdc at J1-L, and -18 to -25.2 Vdc at J1-B. Regulation of these input voltages to the +24 Vdc, +15 Vdc, and -15 Vdc required by various internal circuits is provided by VR7, VR3 and Q11, and VR1 and Q1, respectively.

2-8. Mechanical Functions of the Trainer (fig. 2-19).

a. Firing Sequence.

(1) The trainer mechanical firing sequence is initiated when capacitor C5 discharges and energizes the firing solenoid (I), refer to paragraph 2-9 for electronic functions of the trainer. Energizing the firing solenoid retracts the solenoid armature (2) which in turn pulls the firing mechanism trigger (3) back against the action of the firing mechanism rod (4). Pulling the trigger back raises the trigger pawl out of the notch in the firing mechanism plunger (5) allowing the firing mechanism plunger spring (6) to drive the firing mechanism plunger backward. When the firing mechanism plunger moves backward it activates the first motion switch S1 (7), and then strikes the firing mechanism hammer (8) causing it to strike the firing pin (9) discharging the cartridge (10).

(2) The receiver (11) vents the expanding gas from the cartridge into the pressure tube (12) forcing the recoil dummy projectile (13) forward. At the same time the gas escapes to the outside through orifices (14) in the receiver. This escaping gas develops the backblast. The pressure of the gas against the recoil dummy projectile, and the rate at which it escapes through the orifices in the receiver develops the recoil.

(3) When the recoil dummy projectile moves forward in the pressure tube it pushes the air in front of it forward. The orifice in the end cap (15) restricts the flow of air as it escapes through it. This causes the air to compress slightly, acting as a brake, snubbing the recoil dummy projectile to a stop before it strikes the end cap.

b. Cocking Sequence.

(1) Pulling the lock release lever (16) down unlatches the breechblock (17) from the receiver. Raising the breechblock pulls the cartridge from the cartridge chamber far enough for manual removal, cocks the firing mechanism, resets the first motion switch S1, and positions the safety lever to the safe position. When the breechblock is closed, the cartridge extractor (18) fits under the rim of the cartridge.

(2) The breechblock is secured to the receiver with a breechblock lanyard (19). The breechblock lanyard serves as a pivot point for the breechblock. The breechblock is connected to the firing mechanism piston (20) by two rigid connecting links (21). Raising and lowering the breechblock moves the firing mechanism piston forward and aft. Raising the breechblock moves the firing mechanism piston and the firing mechanism plunger (5) forward. When the notch in the firing mech-

anism plunger moves forward under the trigger pawl the firing mechanism rod forces the firing mechanism trigger pawl into the firing mechanism plunger notch, locking the plunger in the forward position. Lowering the breechblock moves the firing mechanism piston aft compressing the firing mechanism plunger spring (6) between the plunger and the mechanical drive spring stop applying pressure on the plunger.

(3) The safety lever (22) provides a positive mechanical block. When the safety lever is in the DOWN SAFE position it provides a mechanical block between the firing mechanism plunger and the firing mechanism hammer. If the trainer should be fired when the safety lever is in the DOWN SAFE position, the firing mechanism plunger will strike the safety lever instead of the firing mechanism hammer. When the firing mechanism plunger strikes the safety lever it locks the safety lever in the DOWN SAFE position. The firing mechanism must now be recocked before the safety lever can be placed in the LIFT TO ARM position. When the safety lever is placed in the LIFT TO ARM position the mechanical block is removed, and the firing mechanism plunger is free to strike the firing mechanism hammer.

(4) To reset the recoil dummy projectile insert the cleaning brush handle through the orifice in the end cap, and push the recoil dummy projectile to the rear until it is engaged by the spring tension clip (23).

#### 2-9. Electronic Functions of the Trainer (fig. 2-20).

a. First motion switch S1 is located on the firing mechanism housing and is activated by the firing mechanism plunger. When the firing mechanism is in the cocked position, switch S1 permits LET firing capacitor C5 to charge through the normally closed contacts K2A and applies power to the anode of Q1 through the normally closed contacts K2B.

b. Circuit operation initiates with a trigger input to Q1 which energizes K1 through the normally closed contacts K2B, closing contact K1A and opening contact K1B. Contact K1A enables the 600 Msecs oscillator and applies power to the anode of Q2 through the normally closed contacts K3A. Opening contact K1B removes a ground to K1 in the monitoring set.

c. At the completion of 600 Msecs a pulse output from Q4 occurs at Terminal T. This pulse is applied to both Q2 and Q3, causing Q2 to conduct energizing K2. Since power is not present at the anode of Q3 at this time, K3 is not energized.

d. When K2 energizes several things happen: power is removed from K1 via K2B permitting it to drop out; the charging path to capacitor C5 is opened via K2A and power is applied to anode of Q3 and the gate of Q5. Q5 will conduct.



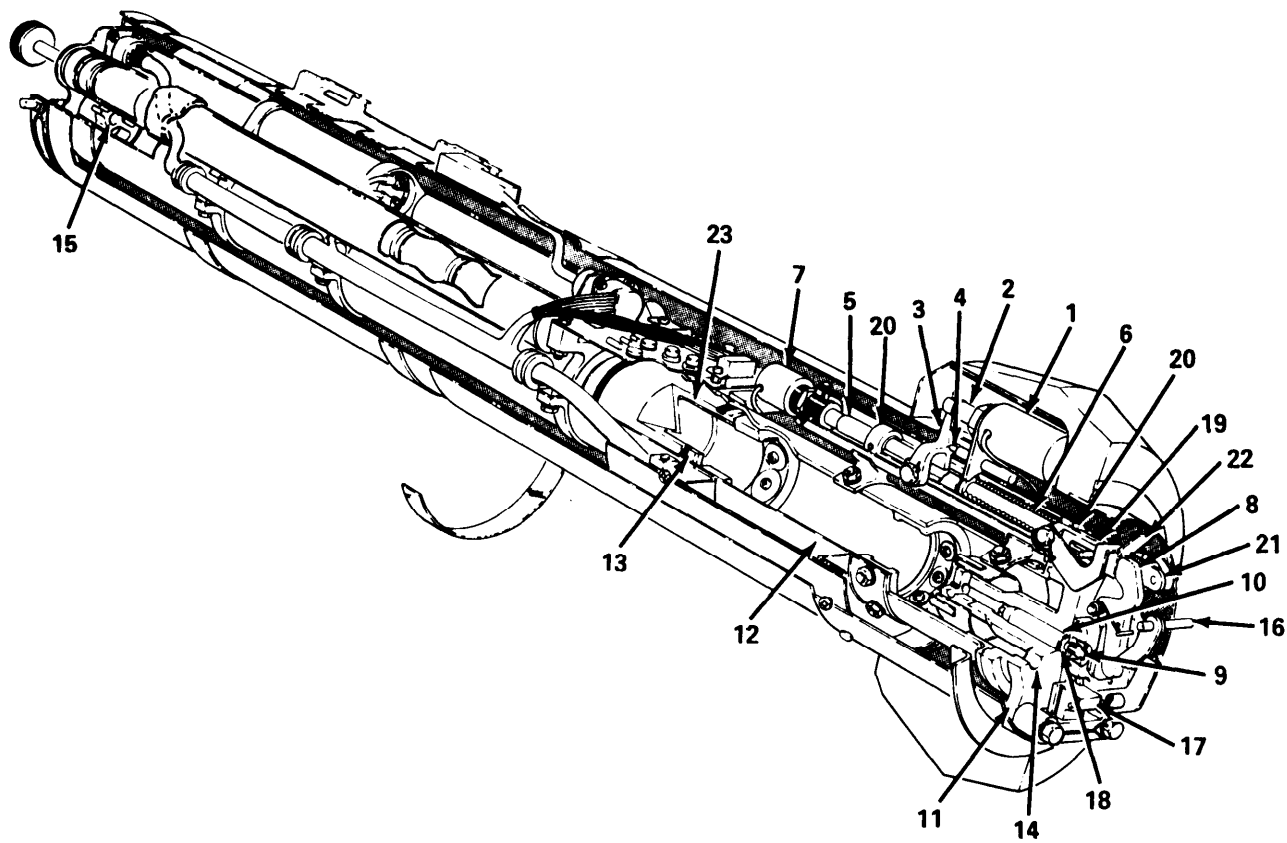

MS 161,642

- |                                   |                            |
|-----------------------------------|----------------------------|
| 1-FIRING SOLENOID                 | 12-PRESSURE TUBE           |
| 2-SOLENOID ARMATURE               | 13-DUMMY PROJECTILE        |
| 3-FIRING MECHANISM TRIGGER        | 14-ORIFICES IN RECEIVER    |
| 4-FIRING MECHANISM ROD            | 15-END CAP                 |
| 5-FIRING MECHANISM PLUNGER        | 16-LOCK RELEASE LEVER      |
| 6-FIRING MECHANISM PLUNGER SPRING | 17-BREECHBLOCK             |
| 7-FIRST MOTION SWITCH S1          | 18-CARTRIDGE EXTRACTOR     |
| 8-FIRING MECHANISM HAMMER         | 19-BREECHBLOCK LANYARD     |
| 9-FIRING PIN                      | 20-FIRING MECHANISM PISTON |
| 10-CARTRIDGE                      | 21-RIGID CONNECTING LINK   |
| 11-RECEIVER                       | 22-SAFETY LEVER            |
|                                   | 23-SPRING TENSION CLIP     |

Figure 2-19. Mechanical functions of the Trainer.

e. Q3 will not conduct at this time. Q3 operation is discussed in subparagraph h. below.

f. When Q5 conducts, it permits capacitor C5 to discharge through the firing solenoid armature activating the solenoid. Activation of the solenoid initiates firing sequence causing the firing mechanism to operate. Refer to paragraph 2-8 for mechanical functions of the trainer.

g. When the firing mechanism operates, the firing mechanism plunger activates the first motion switch S1, opening contact A and closing contact B. Opening contact A, opens the circuit path to capacitor C5. Closing contact B completes a circuit in the monitoring set to start the monitoring set range program.

h. In the event of misfire, the first motion switch S1 will not open, and K2 will remain energized, however, 600 Msecs later the oscillator will transmit another timing pulse to both Q2 and Q3. At this time, Q3 conducts and K3 will operate through the closed contacts of K2A. K3 operation removes power from K2, permitting it to drop out, and it in turn, drops out K3. The normally closed contact K2A permits the recharge of capacitor C5, and the circuit is returned to its initial state.

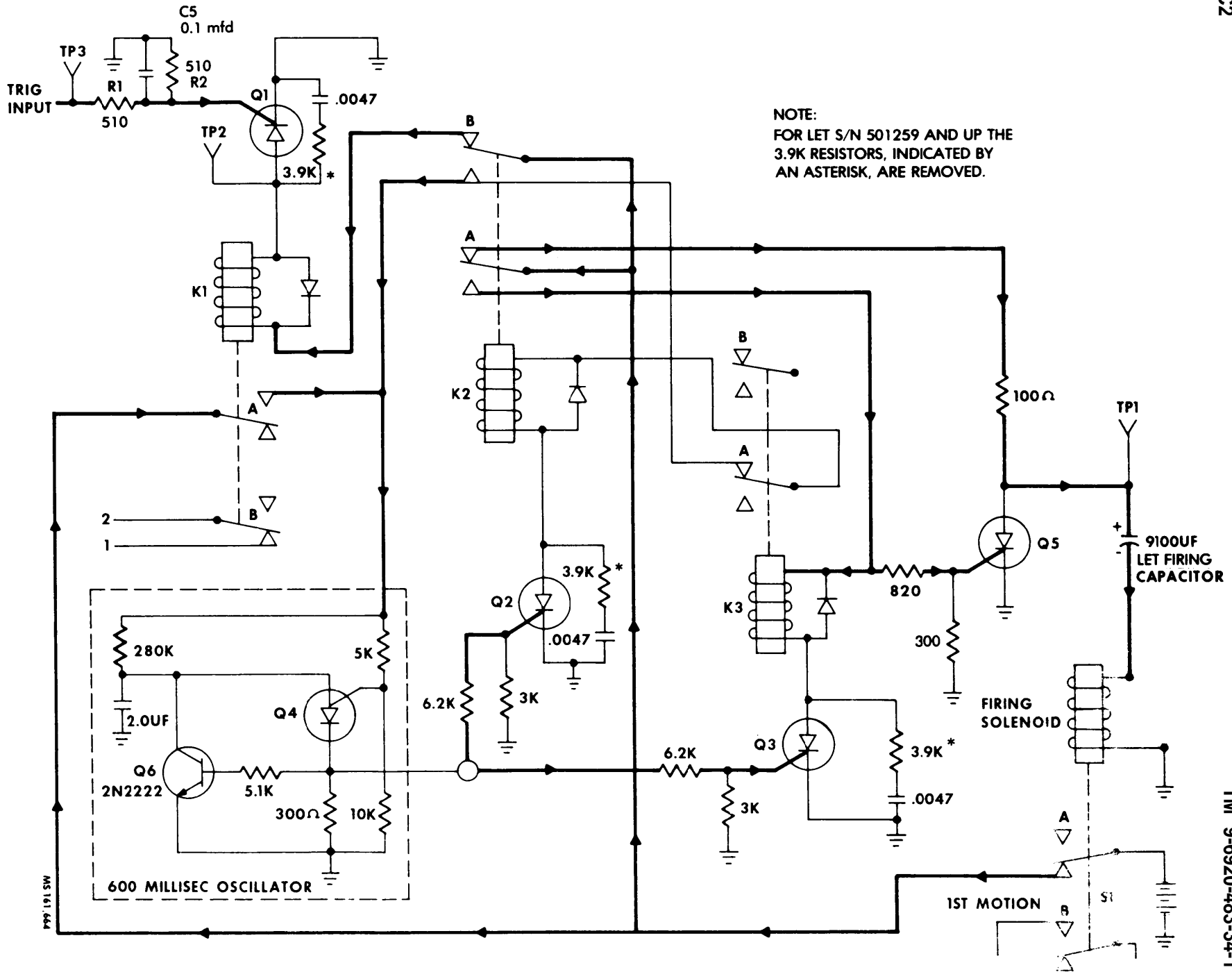
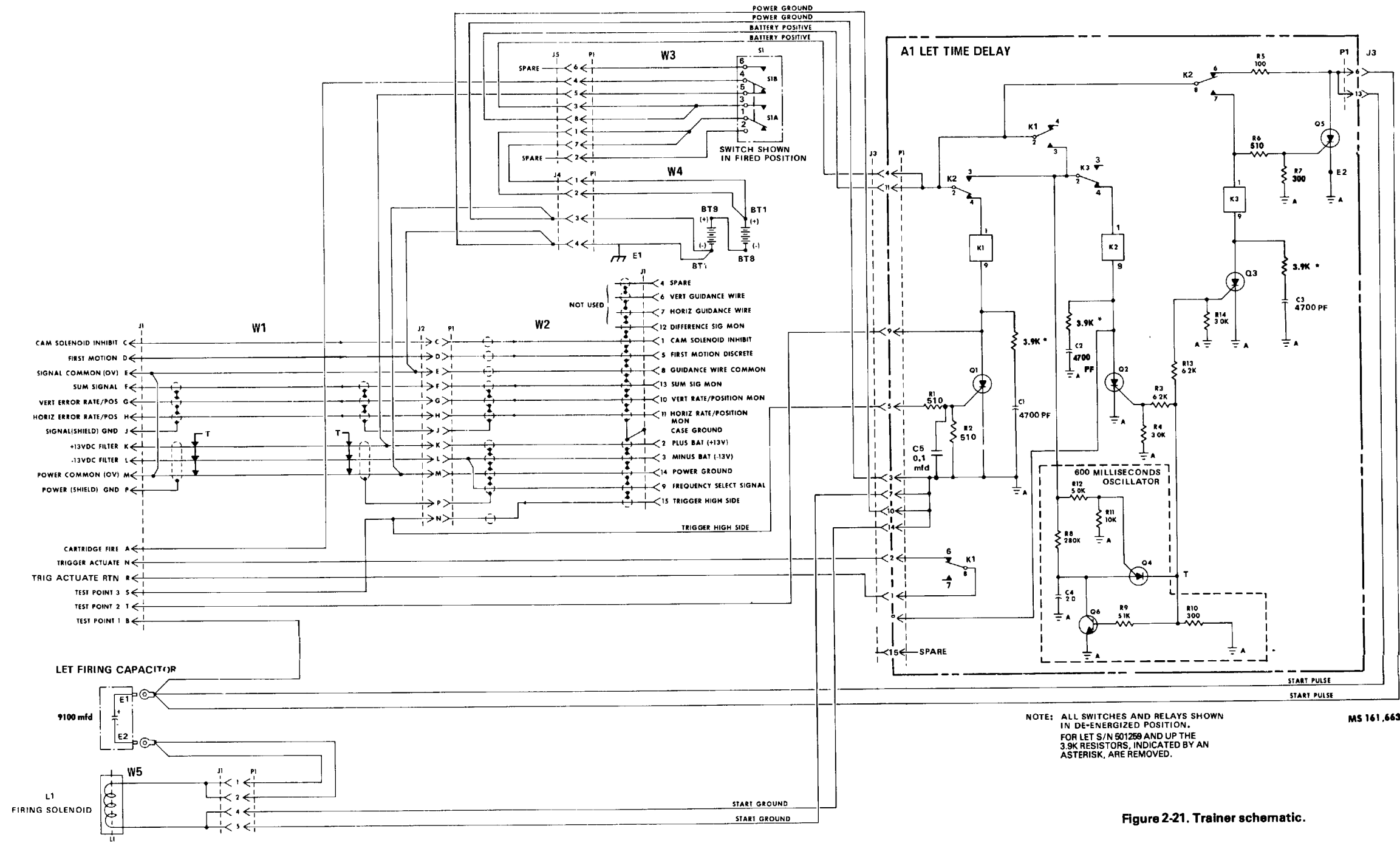

Figure 2-20. Electronic functions of the Trainer

2-91/(2-92 Blank)

MS 161 644





NOTE: ALL SWITCHES AND RELAYS SHOWN IN DE-ENERGIZED POSITION.  
 FOR LET S/N 501269 AND UP THE 3.9K RESISTORS, INDICATED BY AN ASTERISK, ARE REMOVED.

MS 161,663

Figure 2-21. Trainer schematic.



CHAPTER 3  
TROUBLESHOOTING

---

3-1. General

a. Troubleshooting and testing of the MTS and IR transmitter will be accomplished by the procedures contained in TM 9-4935-481-14-1. Alternate troubleshooting and testing procedures for the IR transmitter may also be found in TM 9-6920-483-34-2.

b. Troubleshooting of the LET will be accomplished per TM 9-4935-481-14-1 and TM 9-6920-484-12.

c. Refer to the schematic diagrams and component location diagrams in this chapter and in chapter 2 to supplement the check procedures in TM 9-4935-481-14-1 for the MTS and IR transmitter, for TM 9-6920-483-34-2 for the IR transmitter.

d. Refer to TM 9-1425-484-24 for schematic diagrams for the LET.

e. Refer to chapter 4 for subassembly removal and replacement procedures and for repair procedures,





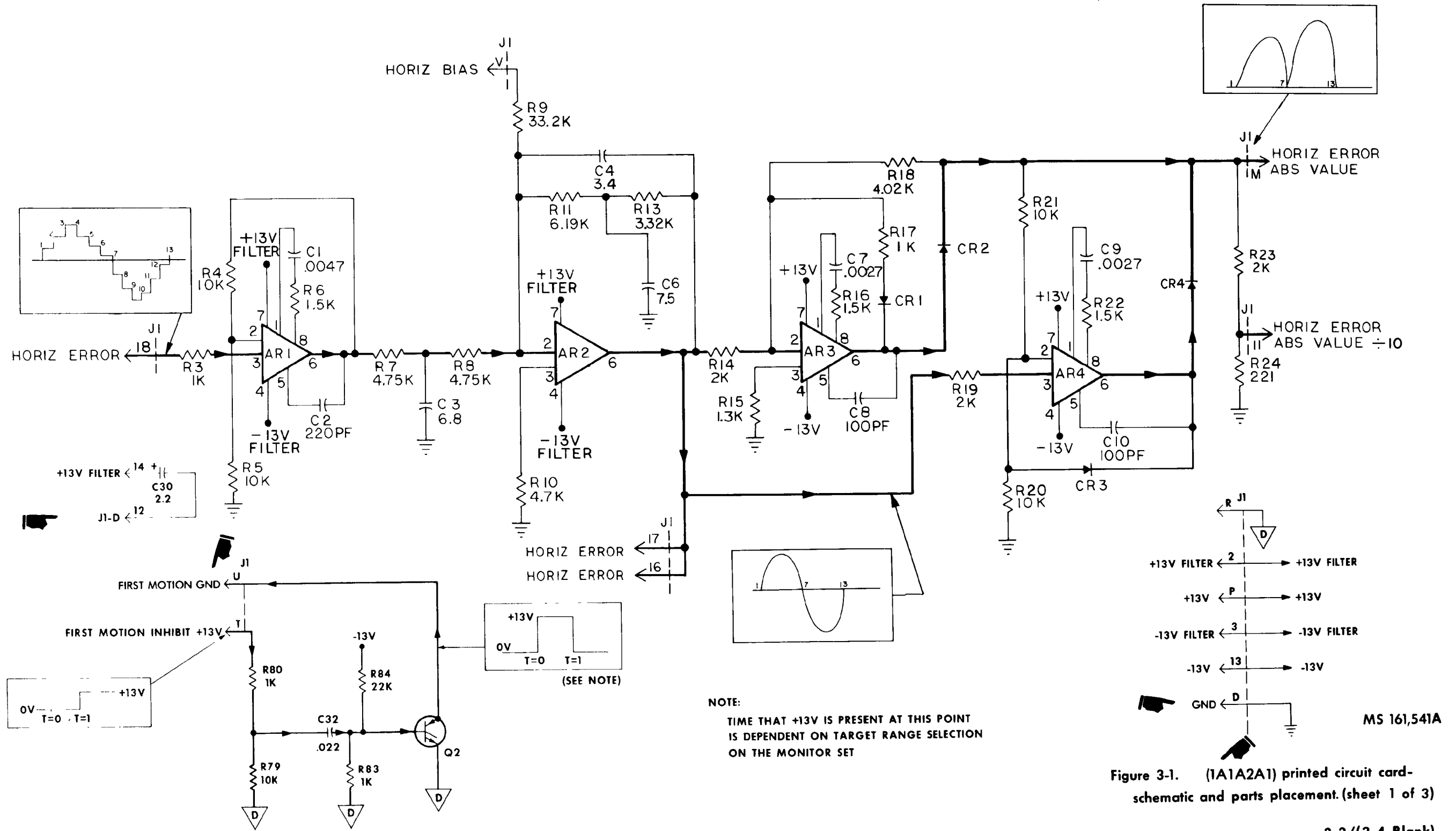

Figure 3-1. (1A1A2A1) printed circuit card-schematic and parts placement. (sheet 1 of 3)



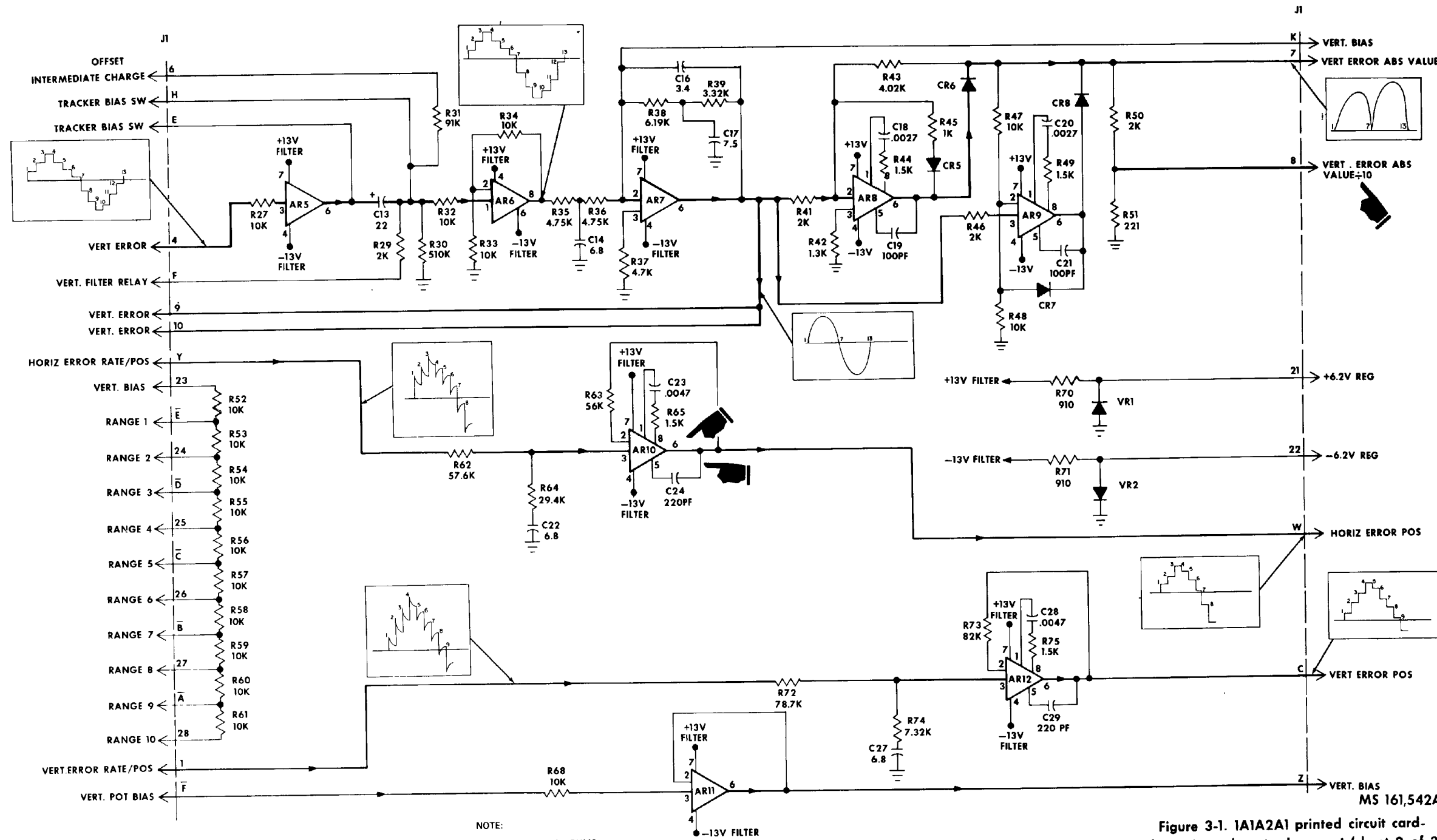
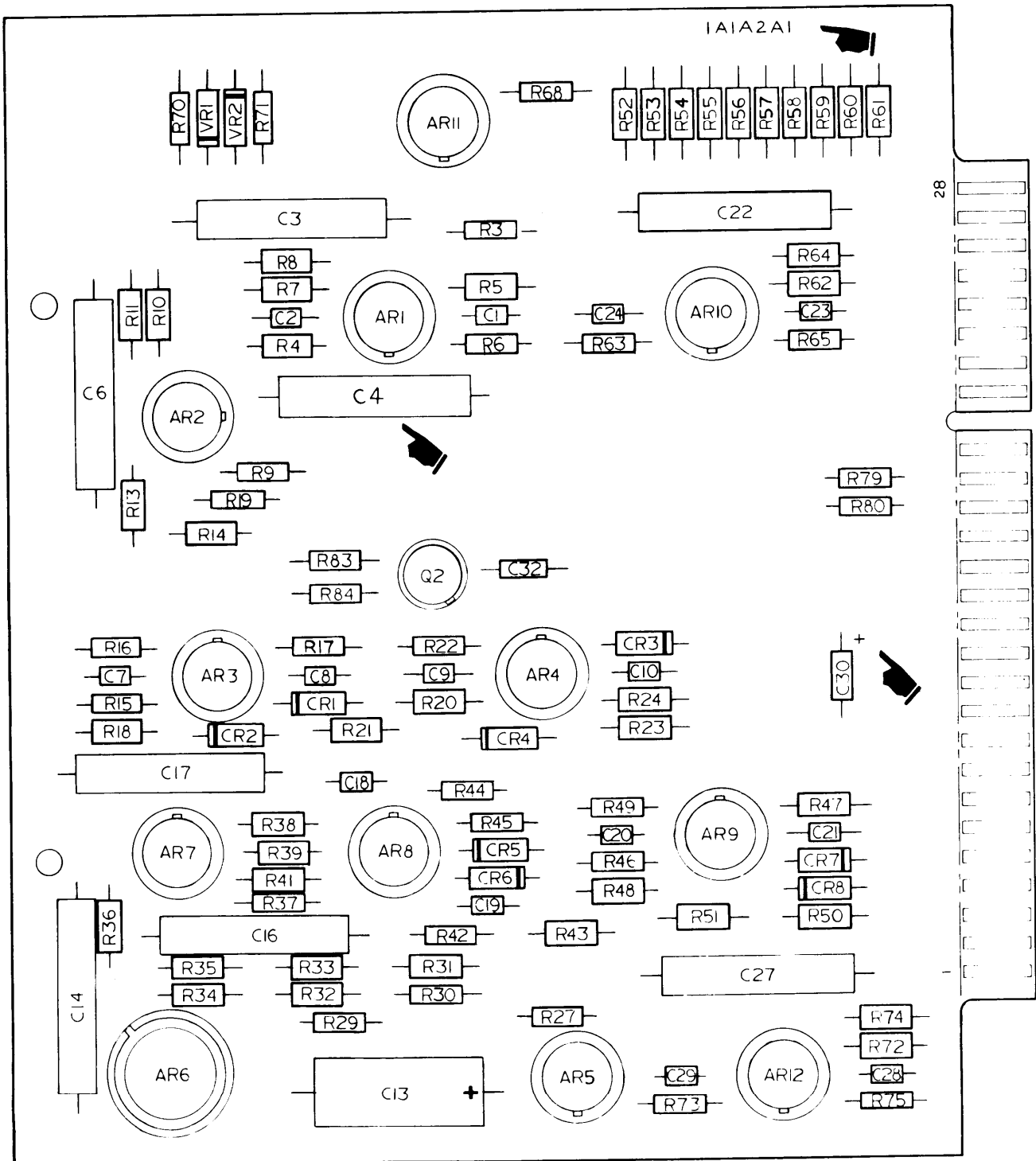

Figure 3-1. 1A1A2A1 printed circuit card-schematic and parts placement. (sheet 2 of 3)





MS 161,543A

Figure 3-1. (1A1A2A1) printed circuit card-schematic and parts placement. (sheet 3 of 3)



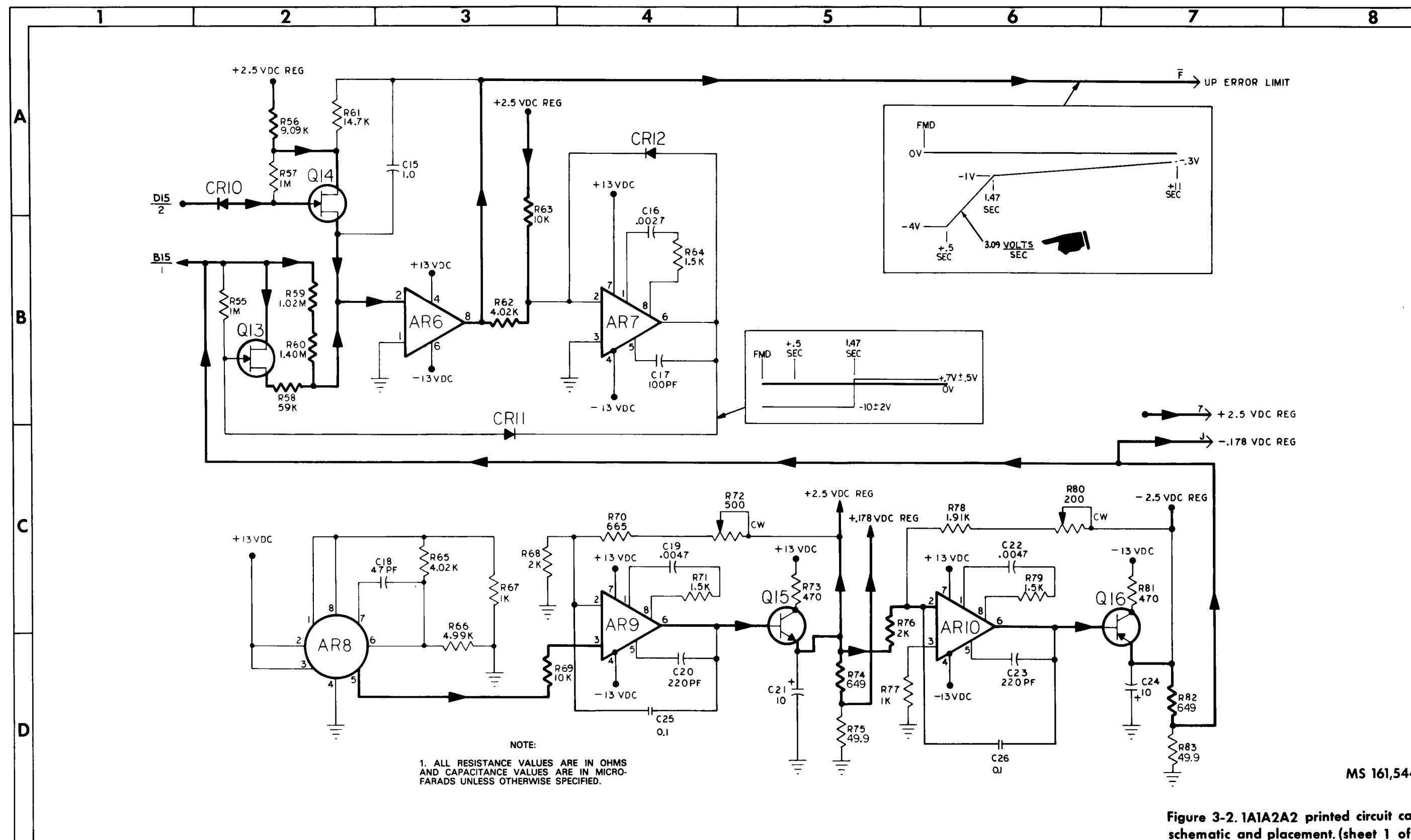

MS 161,544B

Figure 3-2. 1A1A2A2 printed circuit card-schematic and placement. (sheet 1 of 3)





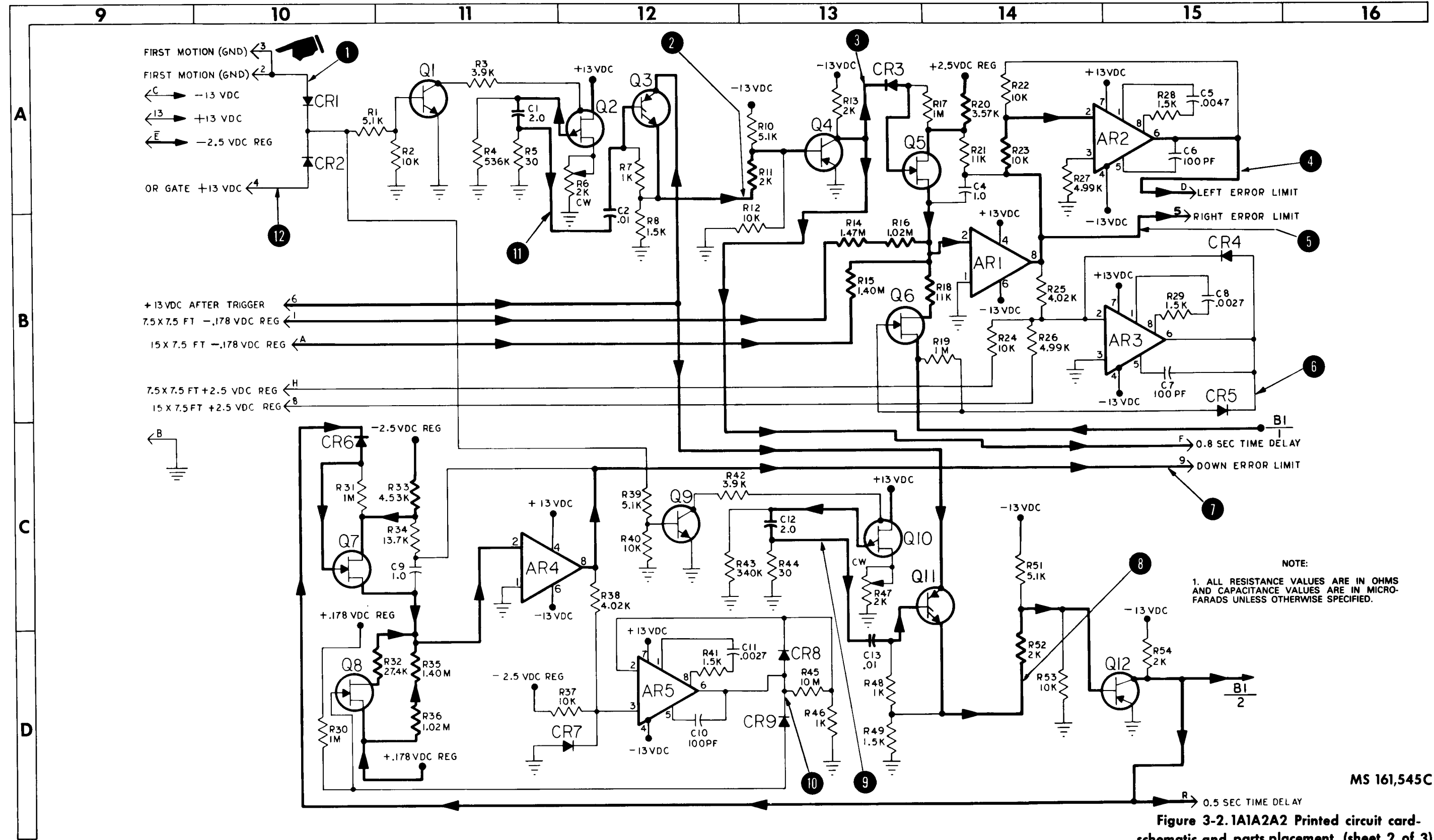

MS 161,545C

Figure 3-2. 1A1A2A2 Printed circuit card-schematic and parts placement. (sheet 2 of 3)



C2

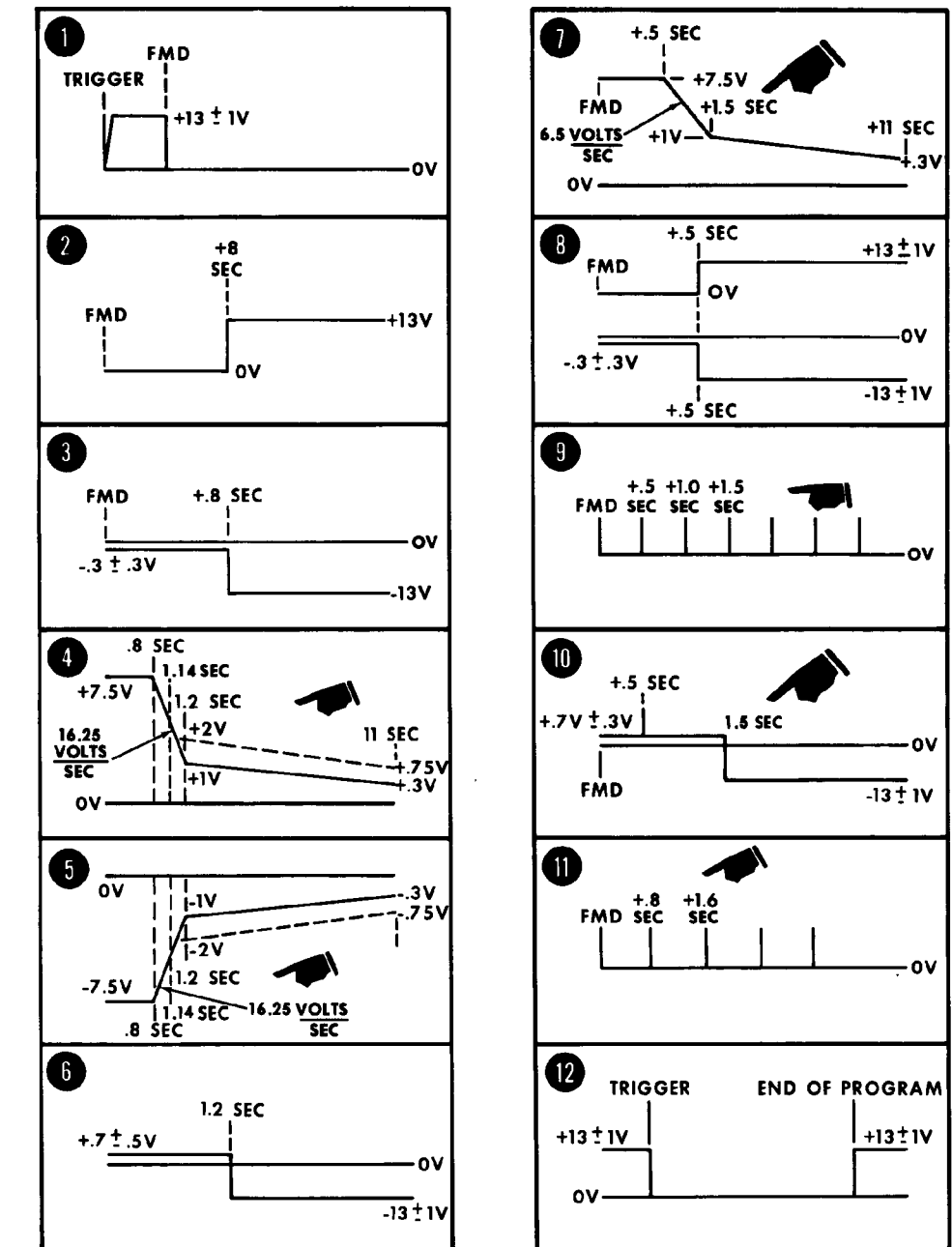
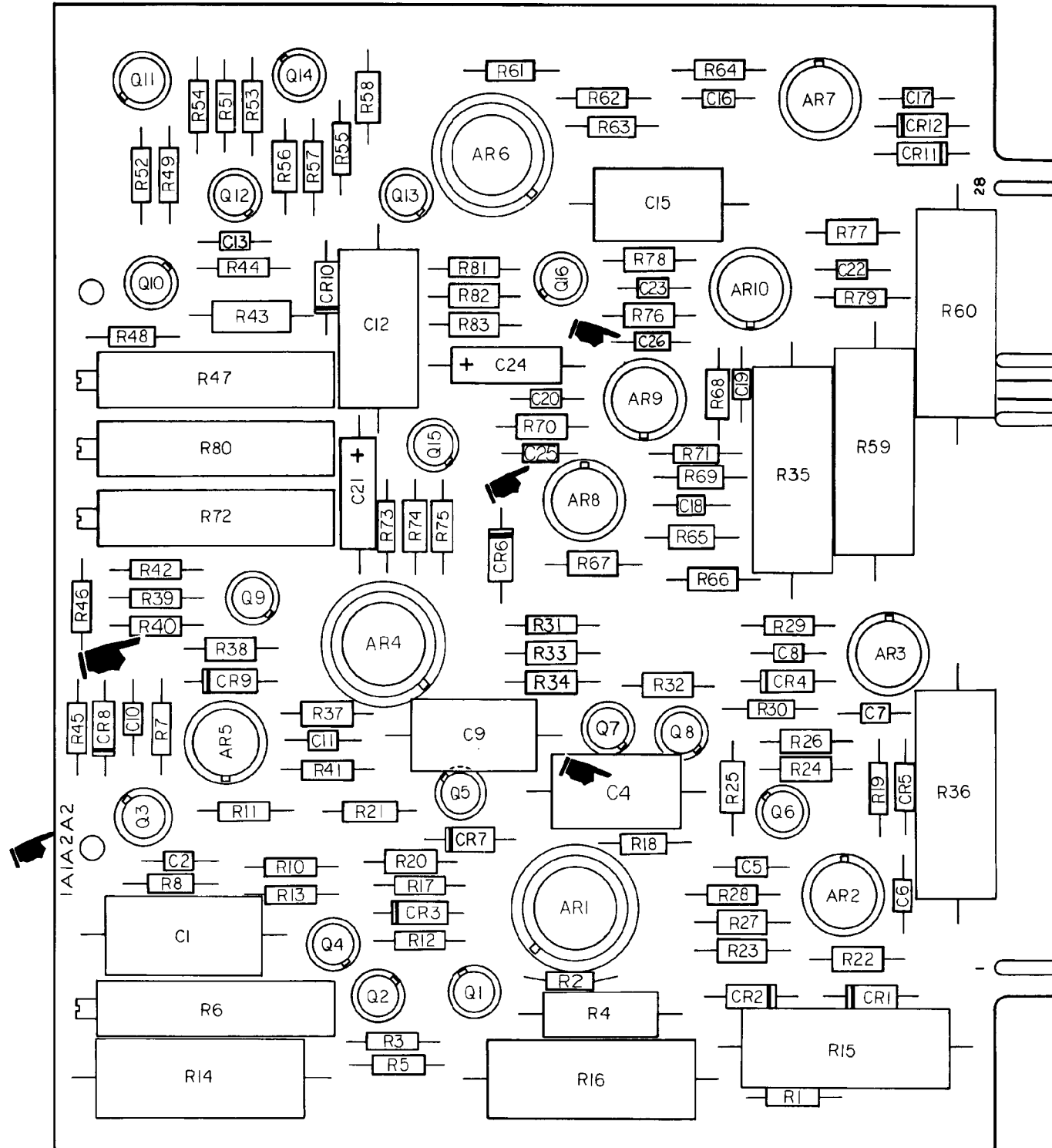

MS 161,546B

Figure 3-2. 1A1A2A2 printed circuit card-schematic and parts placement. (sheet 3 of 3)



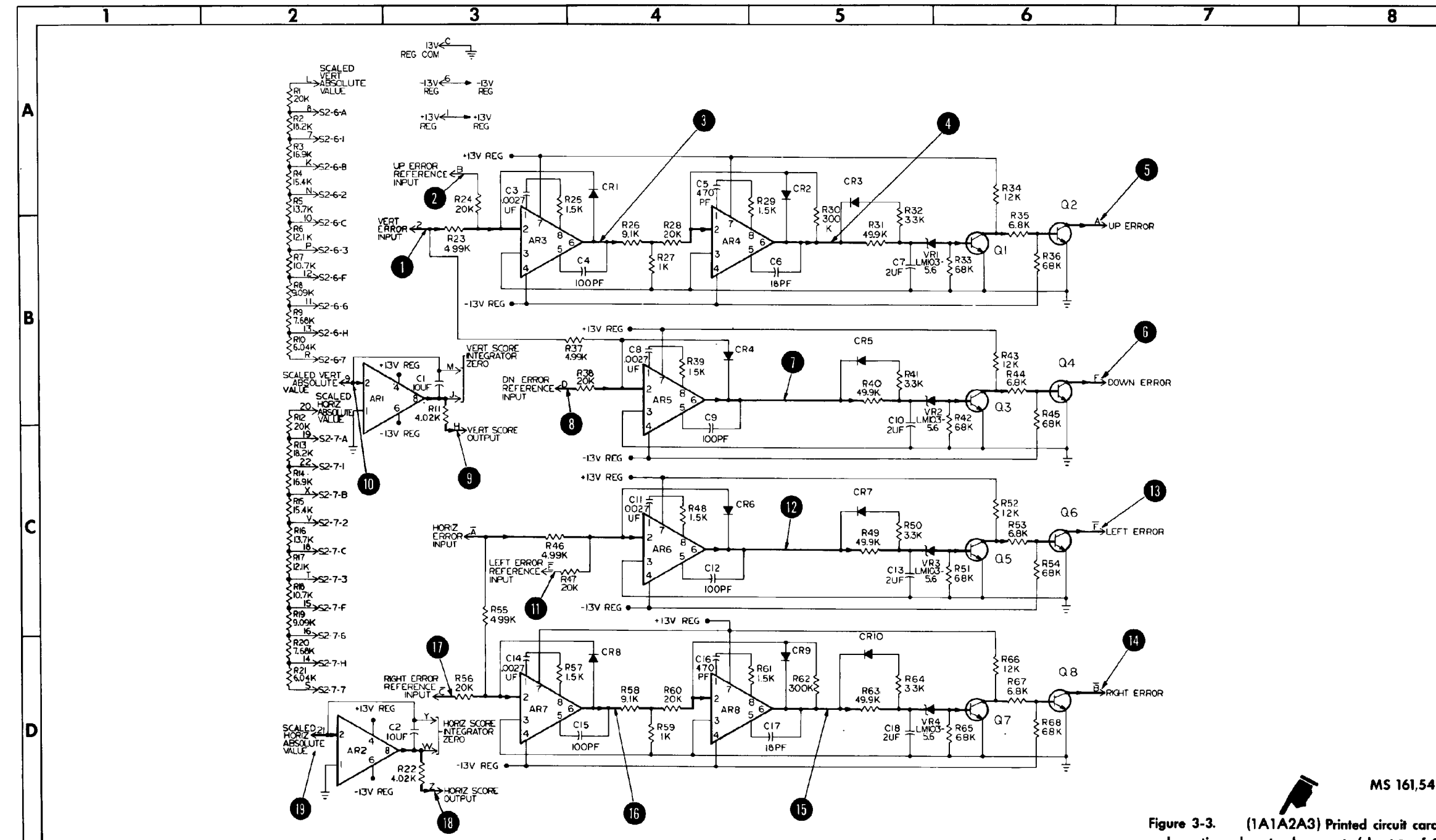

MS 161,547A

Figure 3-3. (1A1A2A3) Printed circuit card-schematic and parts placement. (sheet 1 of 2)



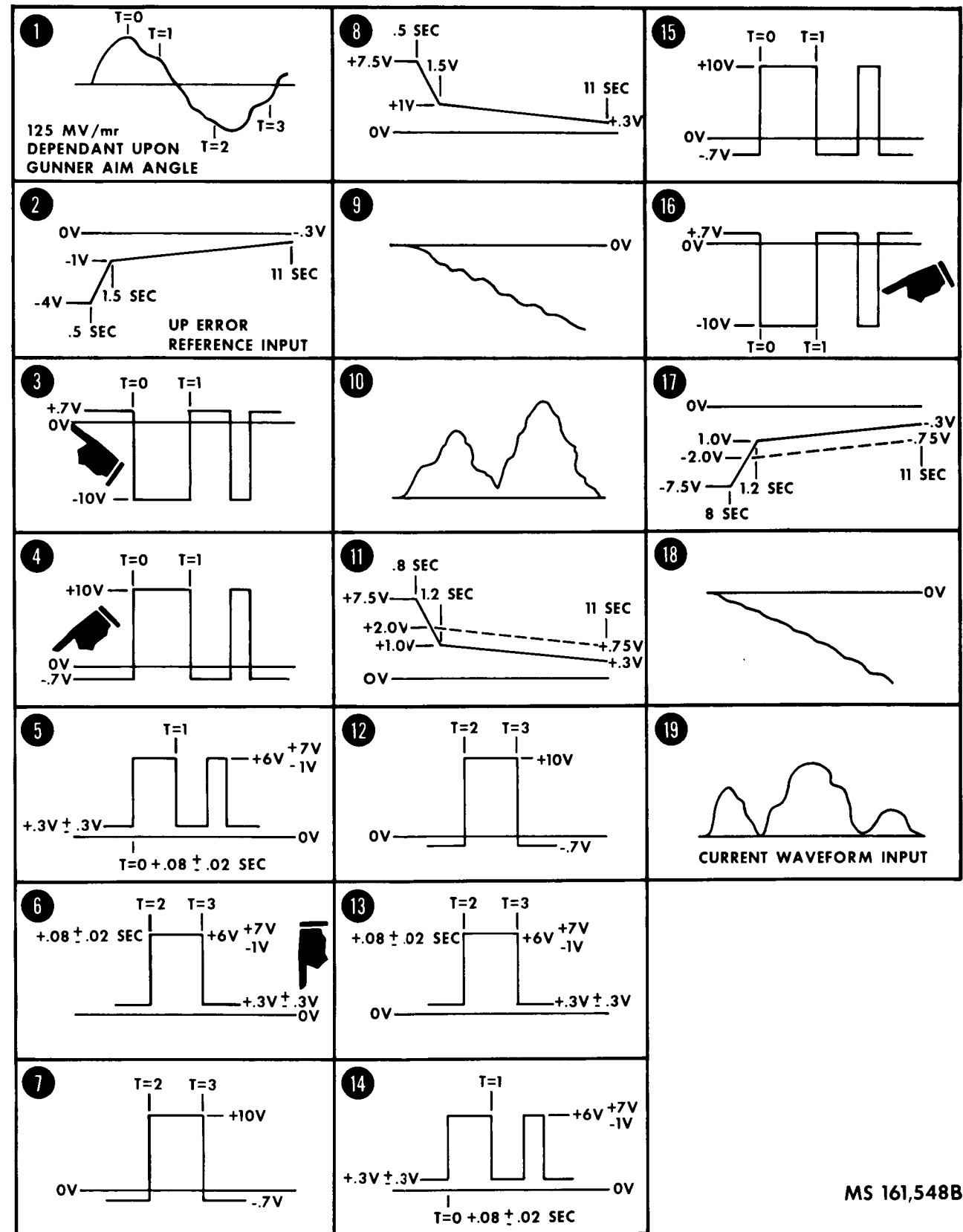
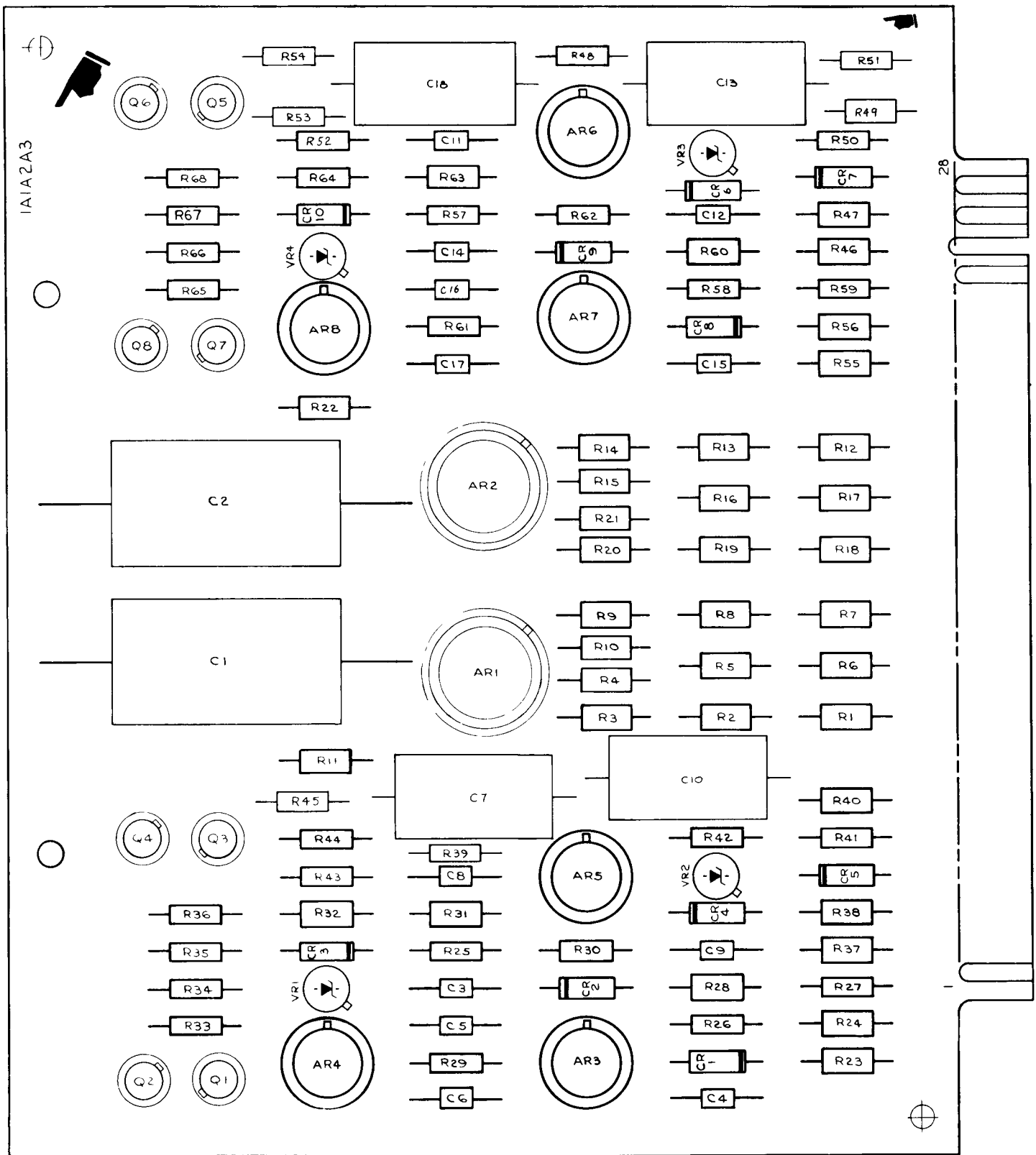

Figure 3-3. 1A1A2A3 printed circuit card schematic and parts placement. (sheet 2 of 2) 3-17/(3-18 Blank)





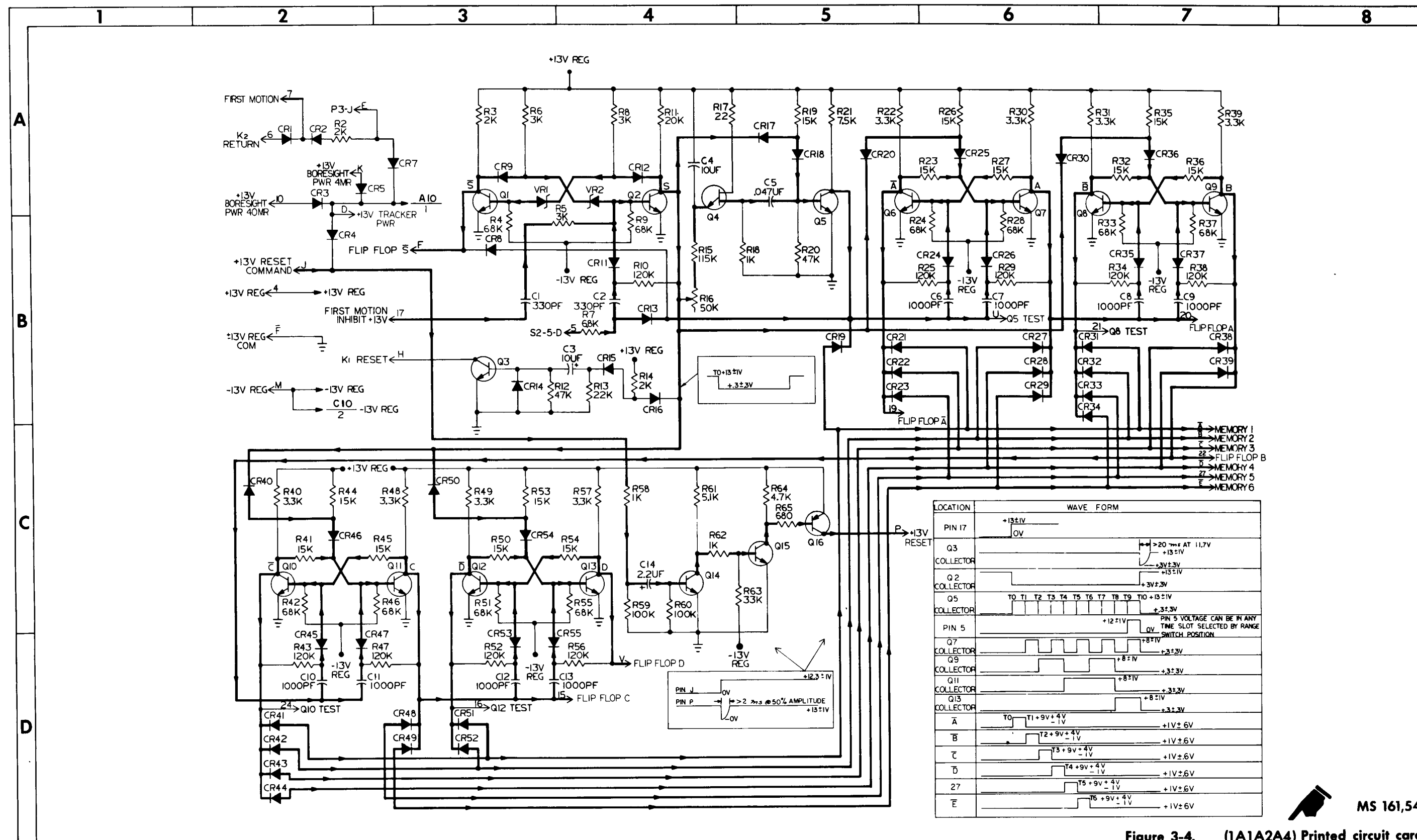
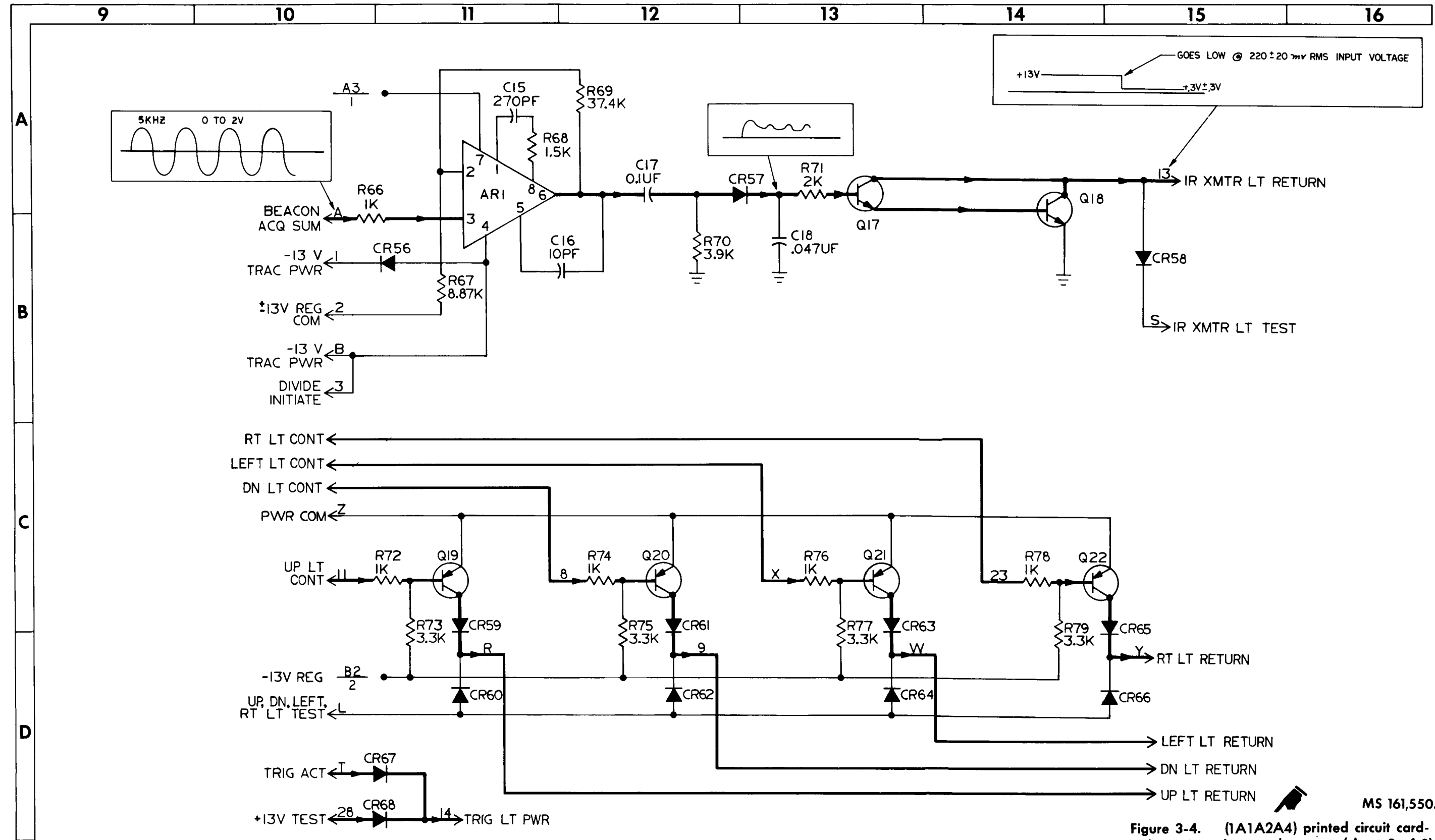

Figure 3-4. (1A1A2A4) Printed circuit card-schematic and parts placement (sheet 1 of 3)

MS 161,549A





MS 161,550A  
 Figure 3-4. (1A1A2A4) printed circuit card-schematic and parts placement. (sheet 2 of 3)







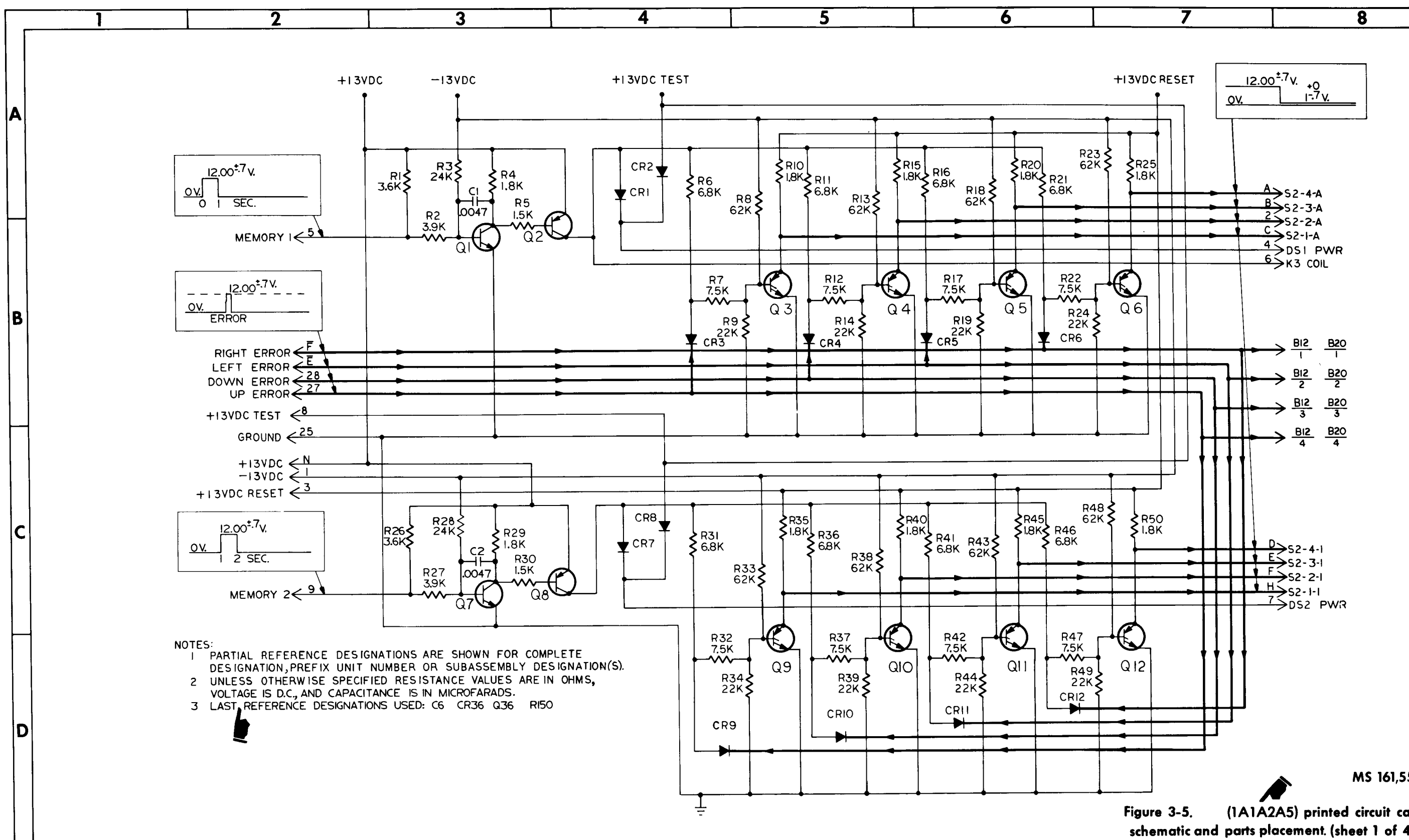

NOTES:  
 1 PARTIAL REFERENCE DESIGNATIONS ARE SHOWN FOR COMPLETE DESIGNATION, PREFIX UNIT NUMBER OR SUBASSEMBLY DESIGNATION(S).  
 2 UNLESS OTHERWISE SPECIFIED RESISTANCE VALUES ARE IN OHMS, VOLTAGE IS D.C., AND CAPACITANCE IS IN MICROFARADS.  
 3 LAST REFERENCE DESIGNATIONS USED: C6 CR36 Q36 R150

MS 161,552A

Figure 3-5. (1A1A2A5) printed circuit card-schematic and parts placement. (sheet 1 of 4)





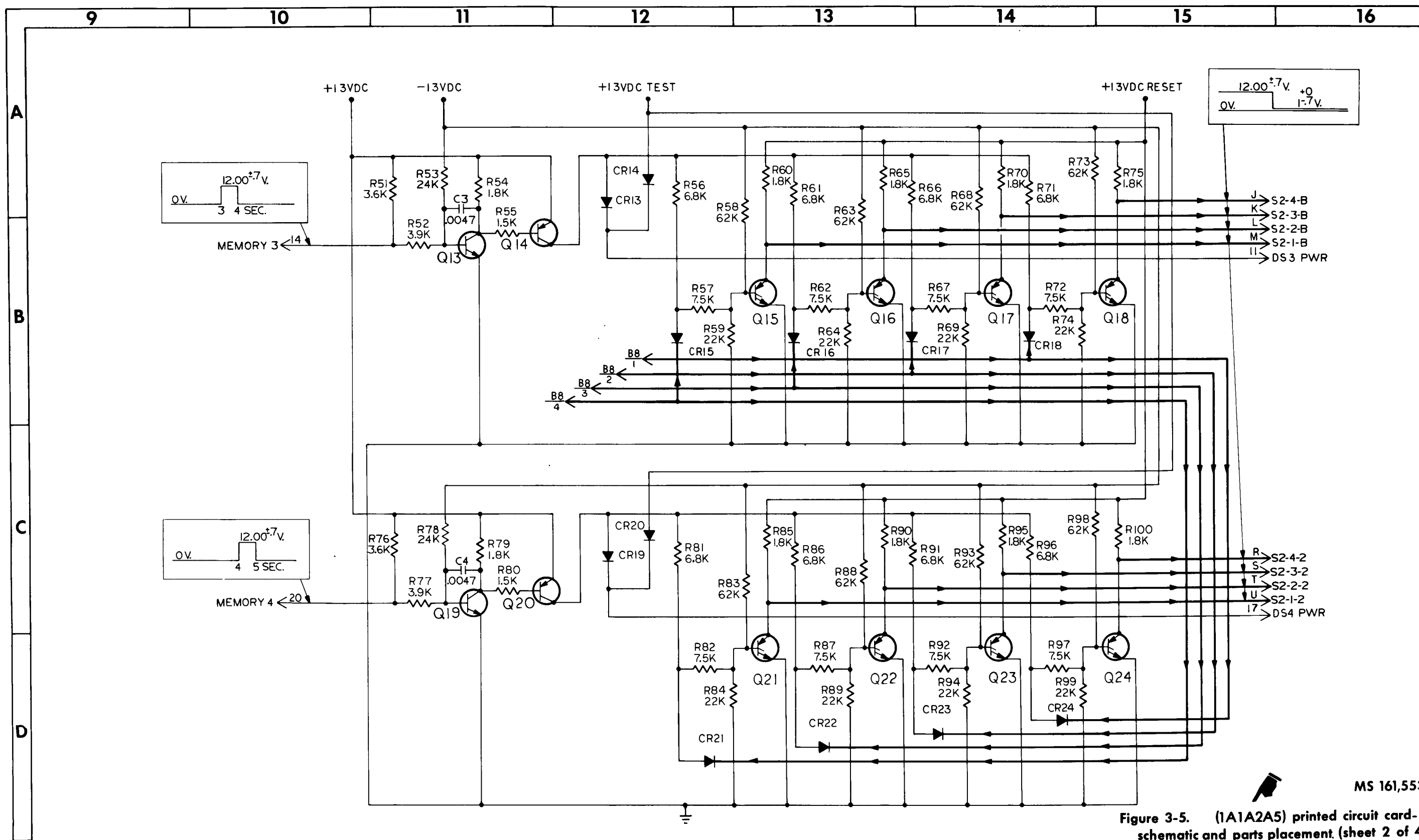

MS 161,553A

Figure 3-5. (1A1A2A5) printed circuit card-schematic and parts placement. (sheet 2 of 4)



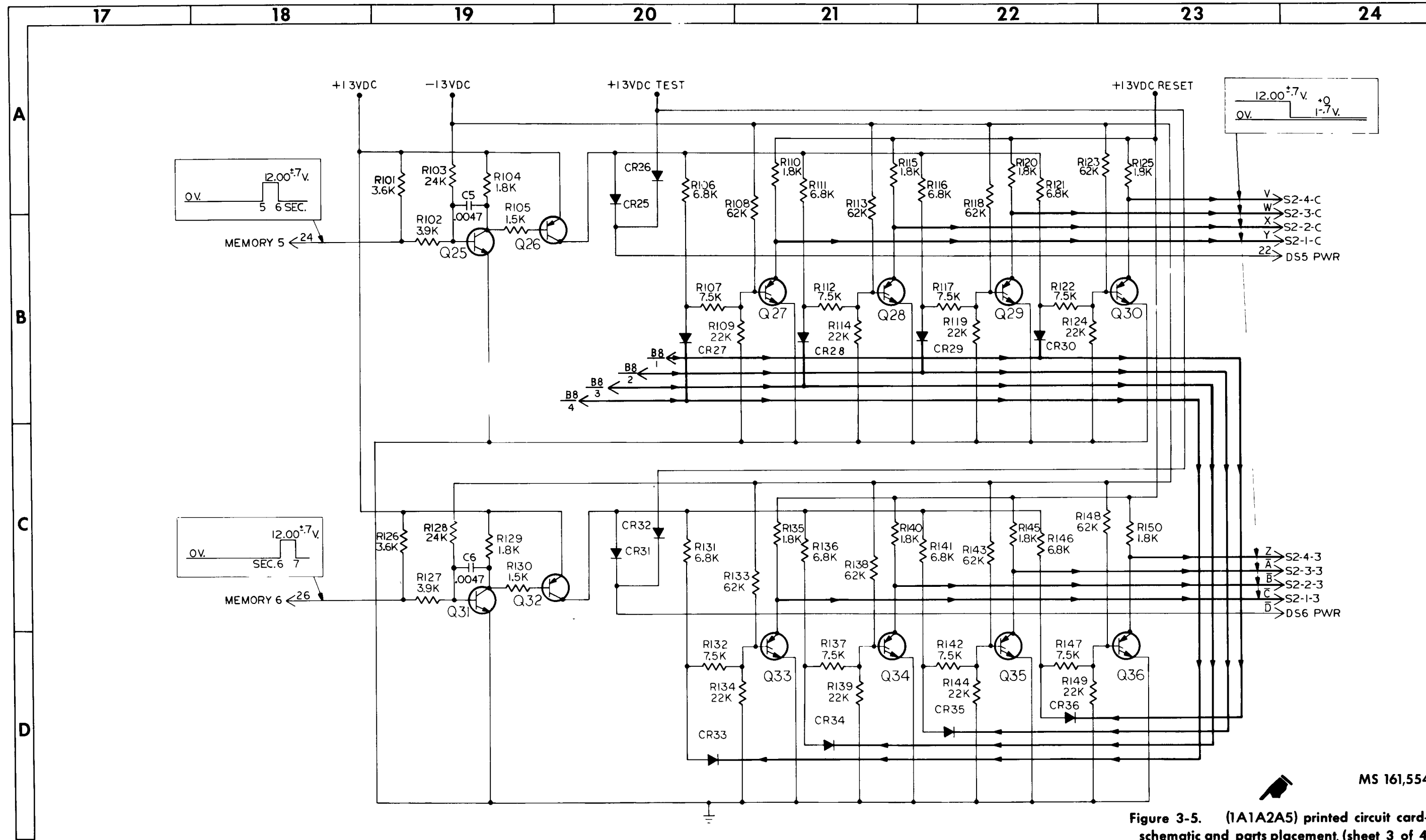

MS 161,554A  
 Figure 3-5. (1A1A2A5) printed circuit card-  
 schematic and parts placement. (sheet 3 of 4)  
 3-29/(3-30 Blank)



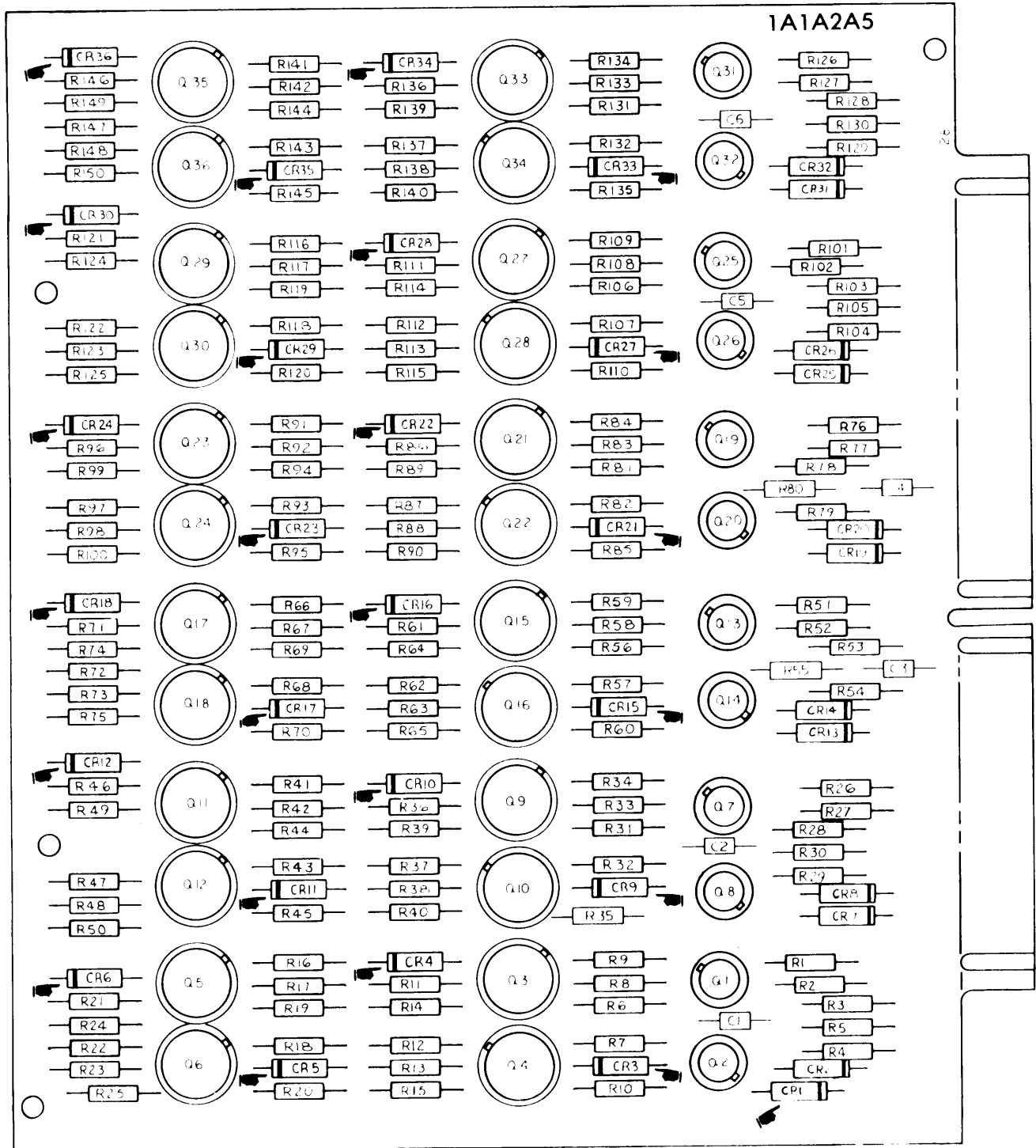

MS 161,555 A

Figure 3-5. (1A1A2A5) printed circuit card-schematic and parts placement. (sheet 4 of 4)



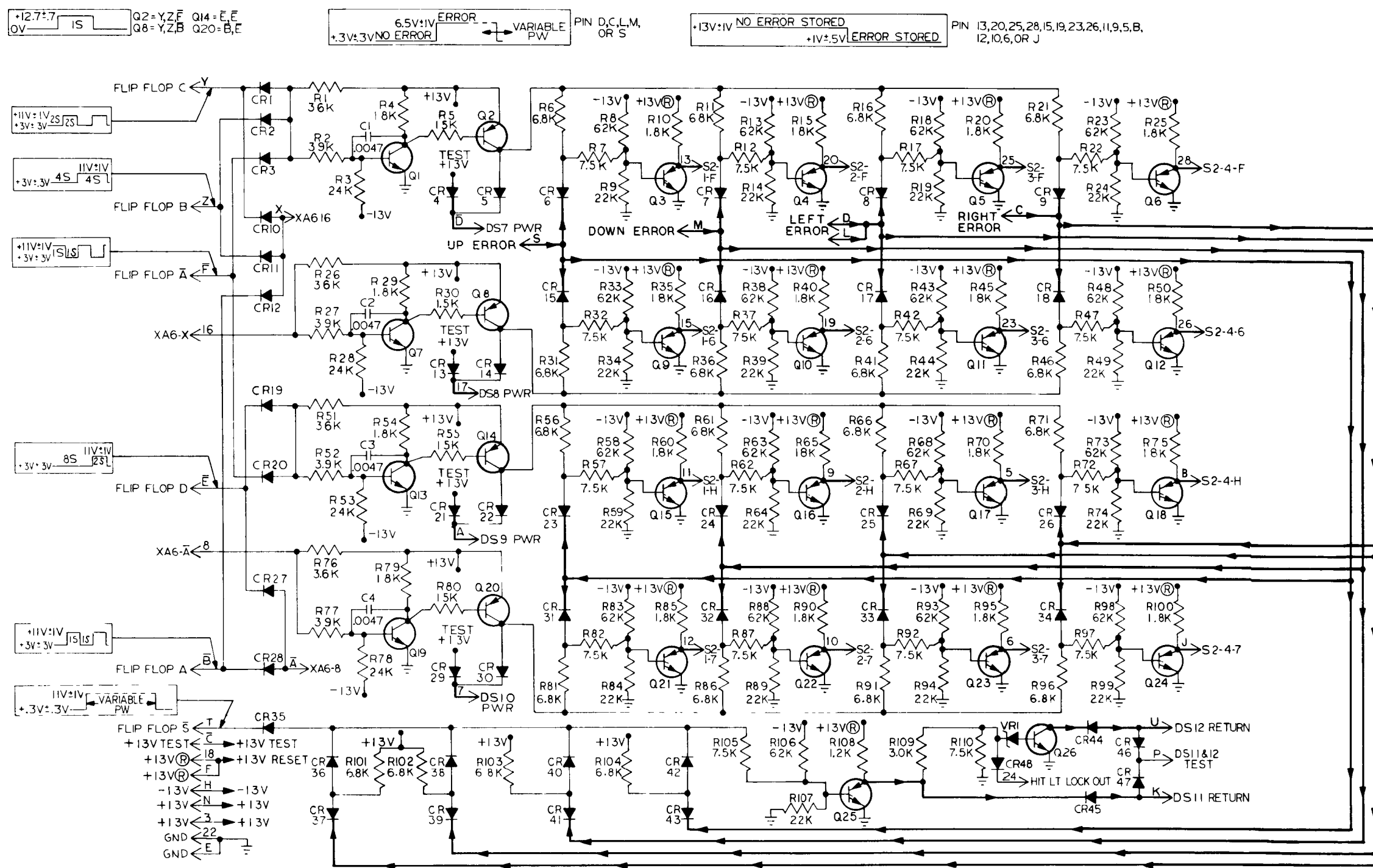

NOTES:

1. PARTIAL REFERENCE DESIGNATIONS ARE SHOWN FOR COMPLETE DESIGNATION, PREFIX WITH SUBASSEMBLY DESIGNATION(S).
2. UNLESS OTHERWISE SPECIFIED RESISTANCE VALUES ARE IN OHMS, VOLTAGES ARE D.C., AND CAPACITANCE ARE IN MICROFARADS.
3. LAST REFERENCE DESIGNATIONS USED R 110 CR 48 Q 26 VRI C 4
4. Ⓢ STANDS FOR RESET.
5. THE FOLLOWING PINS ARE SPARES: V<sub>1</sub>, W<sub>1</sub>, 2, 4, 21, & 27

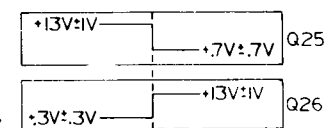
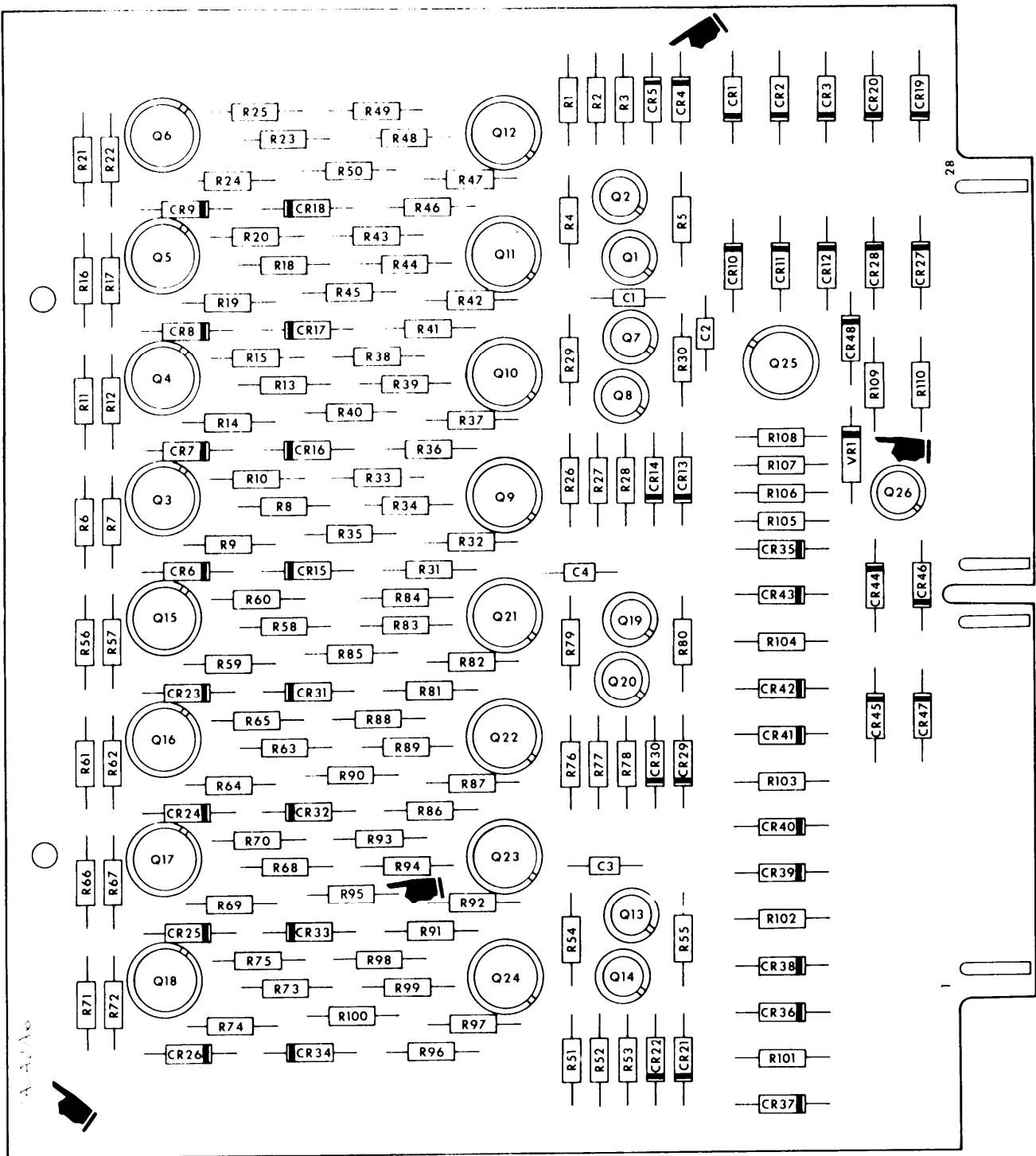

Figure 3-6. (1A1A2A6) printed circuit card-schematic and parts placement. (sheet 1 of 2)

MS 161,556A







MS 161,557 A

Figure 3-6. (1A1A2A6) printed circuit card-schematic and parts placement (sheet 2 of 2)



C1

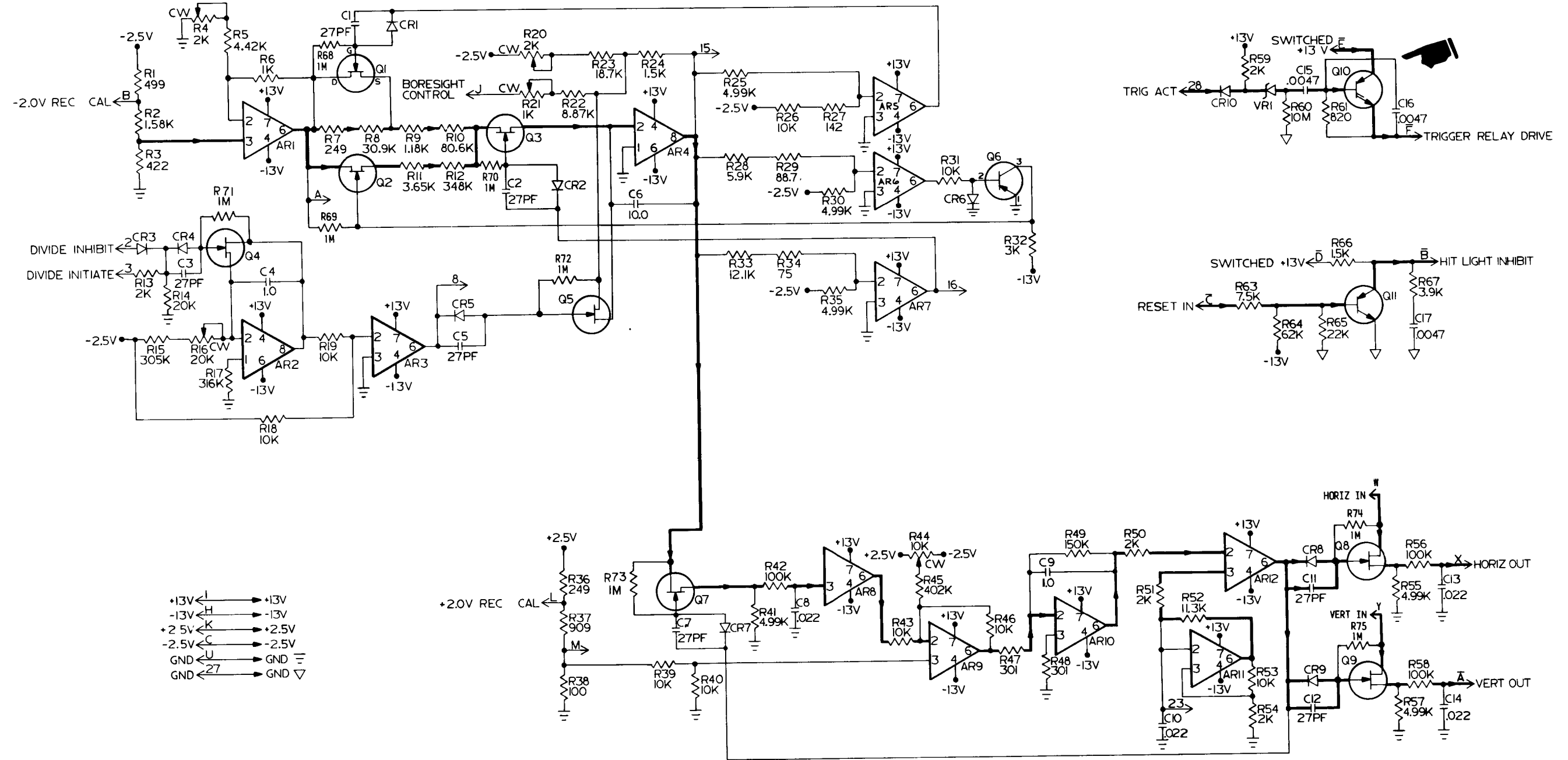

- +13V ← H → +13V
- 13V ← K → -13V
- +2.5V ← L → +2.5V
- 2.5V ← U → -2.5V
- GND ← W → GND
- GND ← 27 → GND

NOTE:

1. ALL RESISTANCE VALUES ARE IN OHMS AND CAPACITANCE VALUES ARE IN MICRO-FARADS UNLESS OTHERWISE SPECIFIED.

MS 161,558A

Figure 3-7. 1A1A2A7 printed circuit card-schematic and parts placement. (sheet 1 of 2)



C2

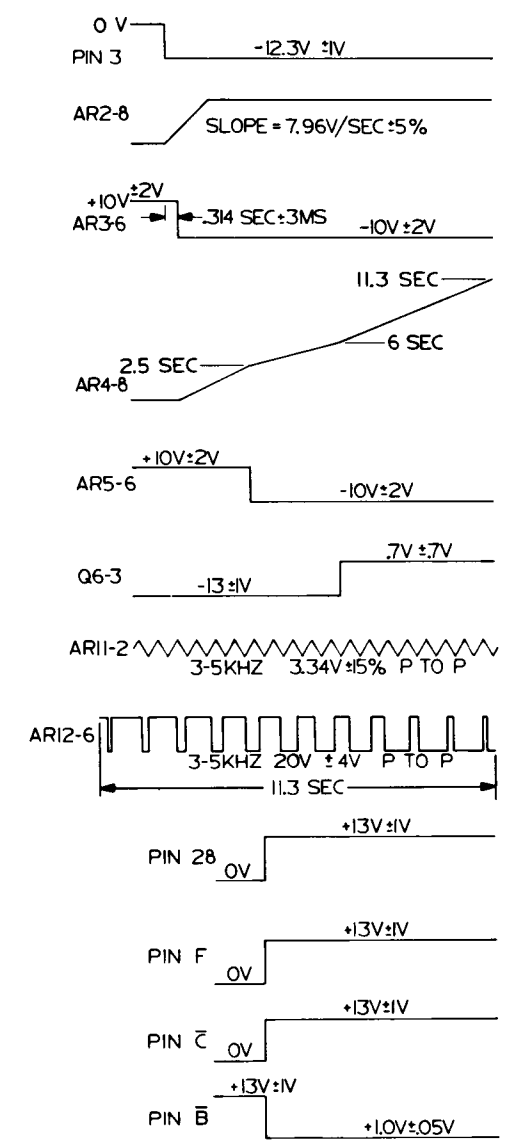
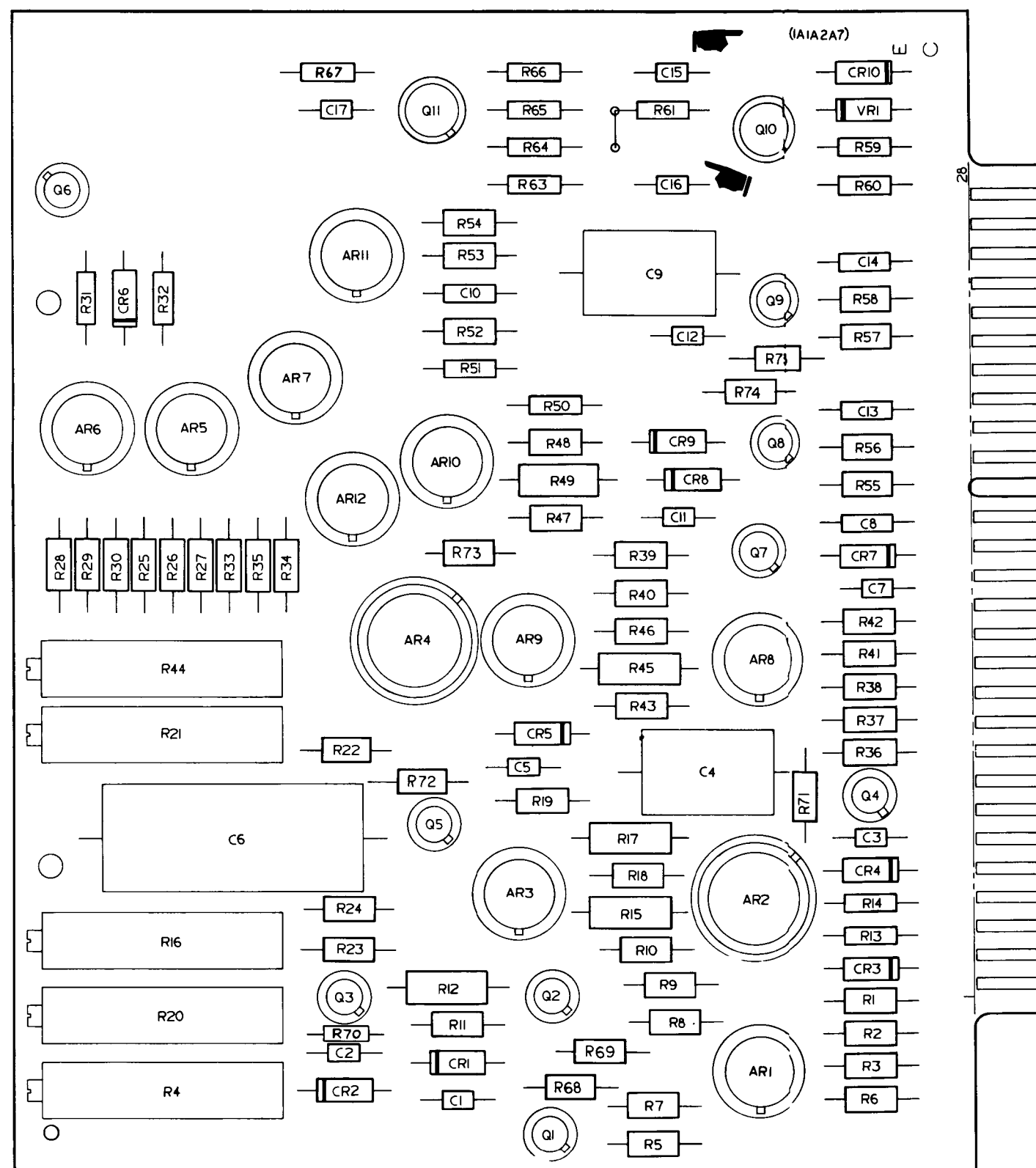

MS 161,559C  
 Figure 3-7. 1A1A2A7 printed circuit card - schematic and parts placement (sheet 2 of 2)



C2

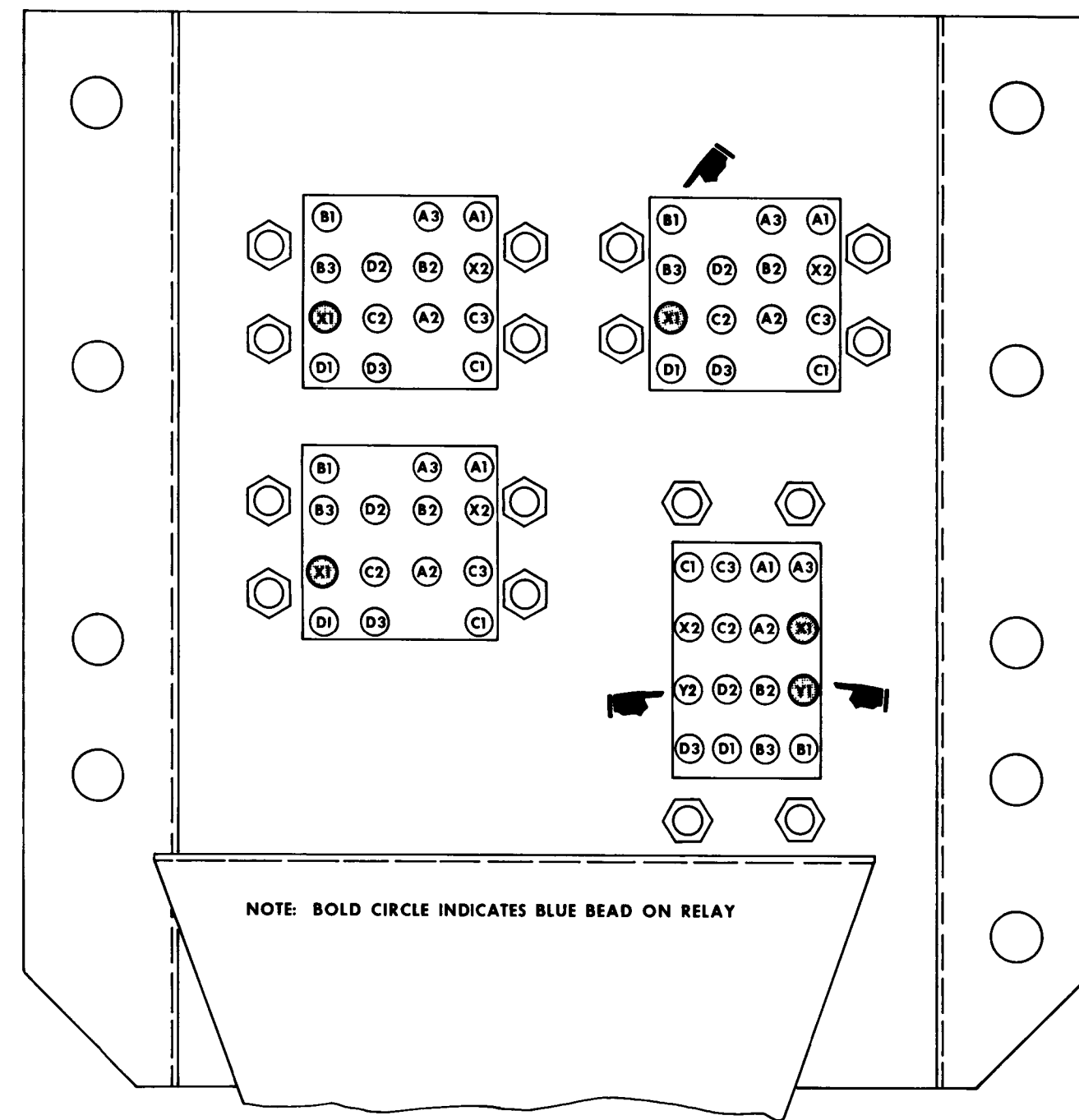
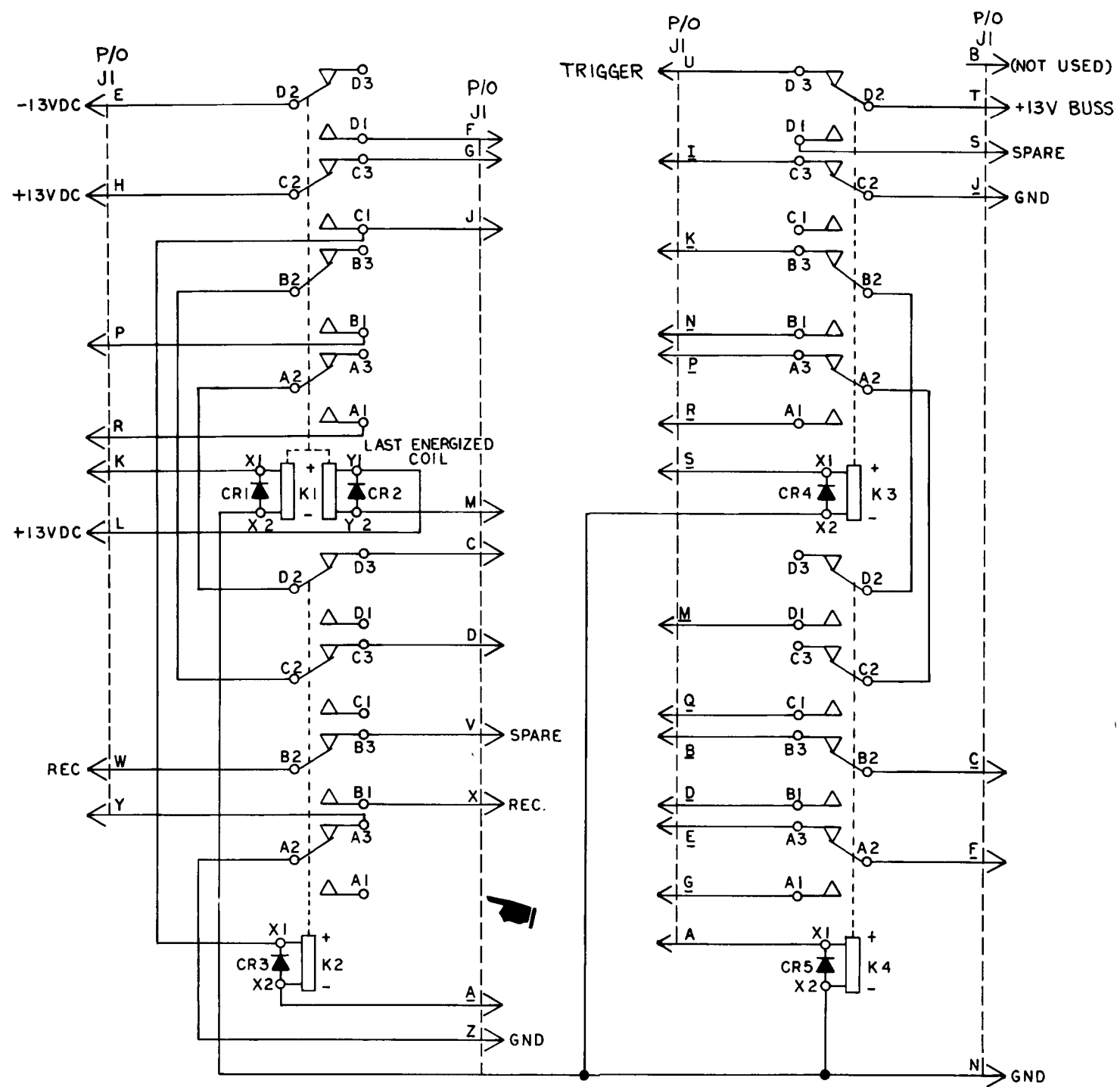

MS 161,560A

Figure 3-8. Relay panel (1A1A3) -schematic and parts placement.





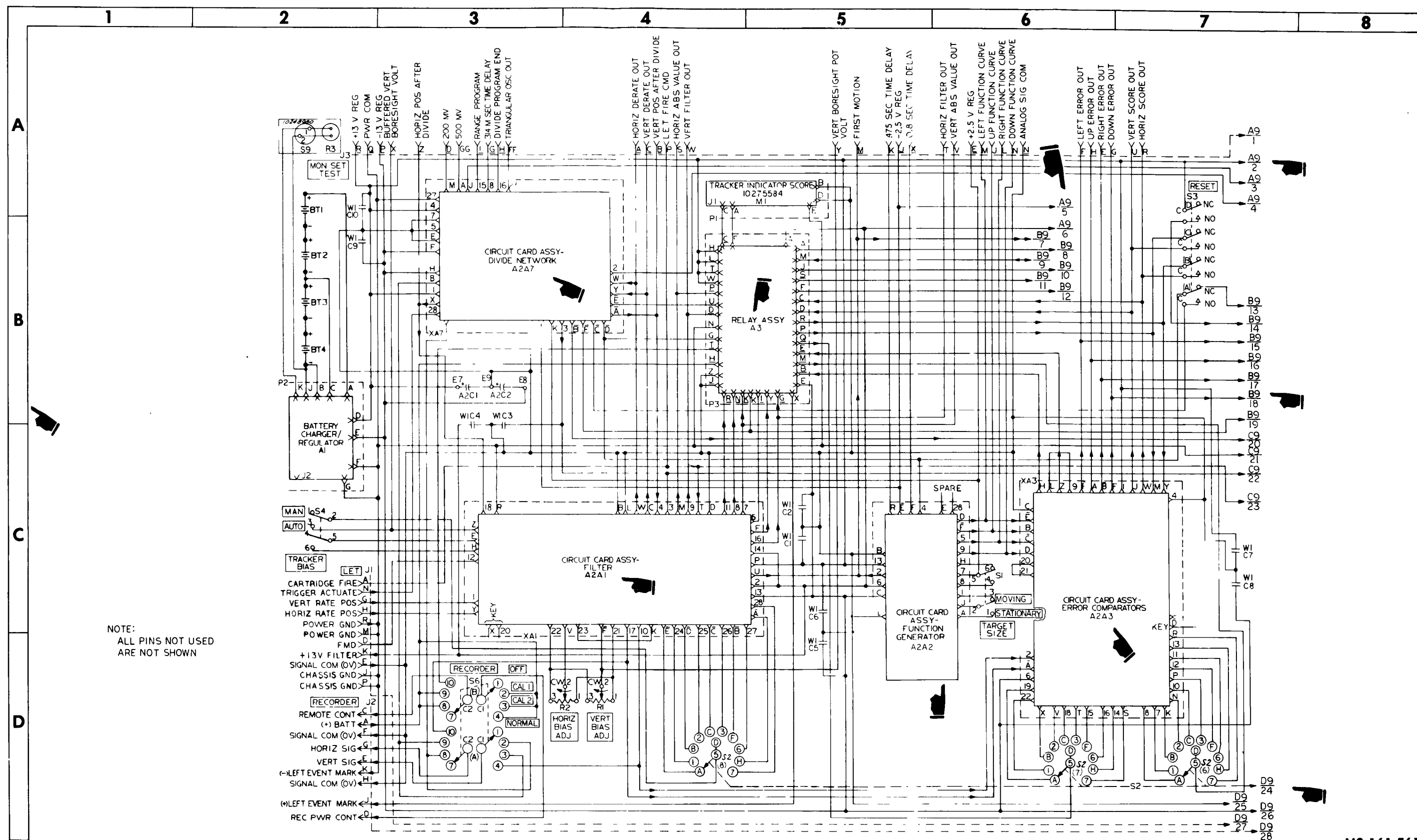

NOTE:  
ALL PINS NOT USED  
ARE NOT SHOWN

Figure 3-9. Monitoring set (10275575)-electrical interface schematic (sheet 1 of 2)



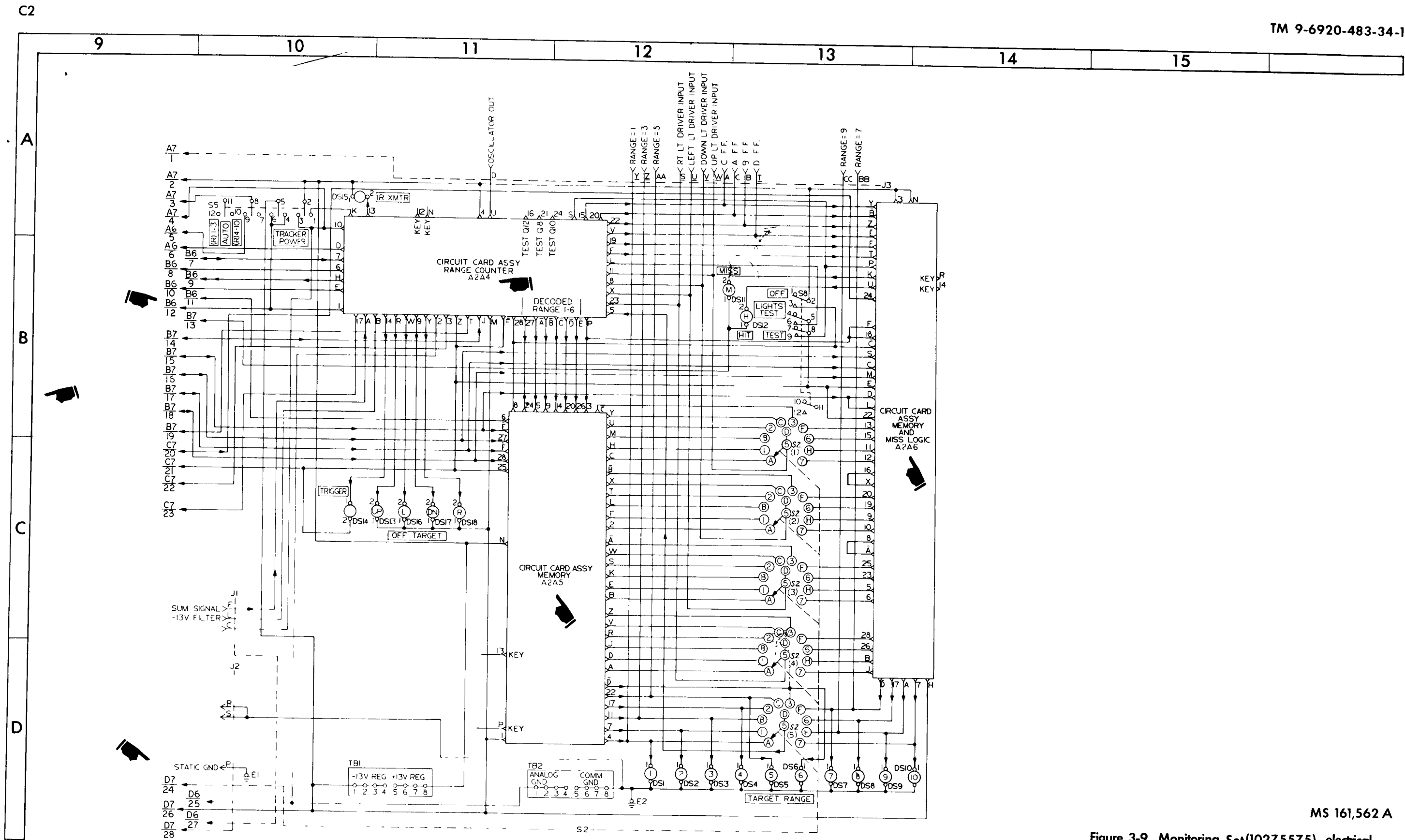

MS 161,562 A  
Figure 3-9. Monitoring Set (10275575) - electrical interface schematic. (sheet 2 of 2)



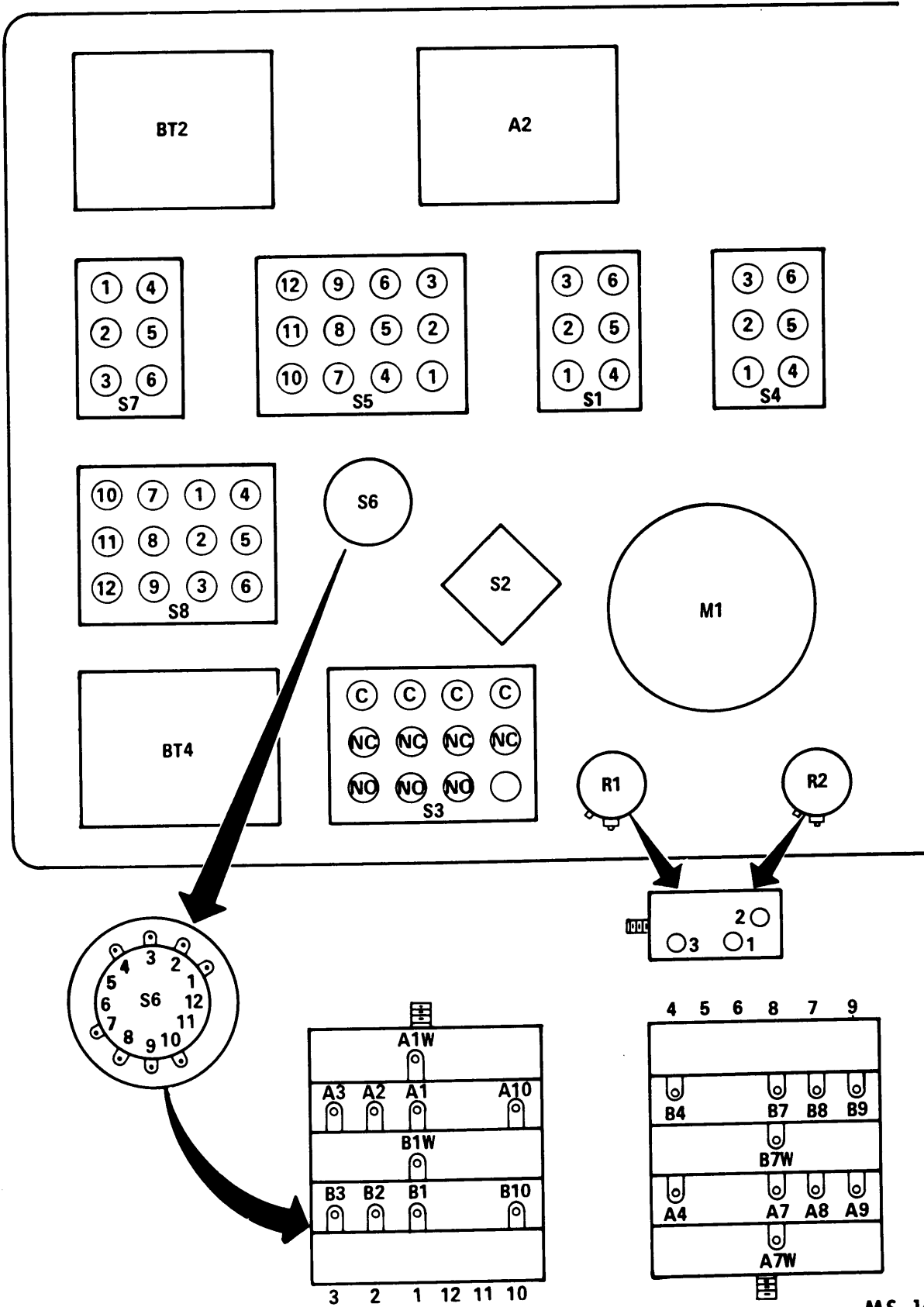

MS 161,563

Figure 3-10 Monitoring Set (10275575)-switch pin positions.



CHAPTER 4  
CORRECTIVE MAINTENANCE

---

4-1. General .

a. This chapter contains data necessary for direct and general support maintenance of the components of the MTS, LET and IR transmitter. These data include alignment, adjustment, removal and installation, disassembly, repair, and assembly instructions pertinent to the training equipment.

b. In most cases, removal and replacement is obvious by illustration (refer to the respective parts manuals for illustrations). Therefore, these procedures will cover only those areas that require special instructions.

c. Paragraph 4-2 contains general maintenance instructions which apply to all items of training equipment.

d. Paragraphs 4-3 through 4-5 provide maintenance instructions for removal, repair, and replacement of assemblies and subassemblies at the direct and general support maintenance levels.

e. Following repair and/or replacement of any items on the MTS, LET, or IR transmitter which affect operation, that piece of equipment will be tested in accordance with procedures contained in TM 9-4935-481-14-1. Alternate test procedures for IR transmitter may be found in TM 9-6920-483-34-2.

f. TM 9-4935-481-14-2 contains a list of general purpose materials used to maintain the training equipment.

g. Refer to TM 9-6920-484-12, TM 9-1425-484-24 and TM 9-6920-483-34-2 for additional maintenance procedures concerning the training equipment.

4-2. General Corrective Maintenance.

WARNING

In view of the toxic and volatile nature of the materials used in the application of adhesives, paints, and conformal coatings, insure the area of application has adequate ventilation. Avoid breathing fumes. Avoid skin and eye contact by wearing protective gloves and goggles. If contact occurs, wash with water and soap and report to a first aid station. Flammables must be kept away from flames, sparks, and excessive heat. Solvents shall be stored in and used from approved safety containers which shall be sealed when not in use. All cloths used for solvent cleaning operation shall be discarded into an approved container.

a. Cleaning. All assemblies must be cleaned after removal and disassembly, prior to assembly and installation.

(1) The range switch wafers and contacts may be cleaned by removing the wafers from the range switch. Avoiding the contacts and circuit area, grasp the wafer with a pair of hemostats and immerse the entire wafer in a jar of freon. Stir wafer in the jar to assure free dirt fallaway. Remove wafer from solution and shake off excess freon. Do not wipe!

(2) The contact area can be cleaned by dipping a clean piece of mylar in freon and sliding back and forth under each contact.

b. Repair.

(1) Removal and reapplication of conformal coating (polyurethane).

(a) Removal.

CAUTION

Unresolve Plus S.G. must be confined to the affected work area only.

It attacks most plastics and must not be spilled on other parts.

1. Conformal coatings may be removed with Unresolve Plus S.G. This solvent may be used as either a liquid or a gel. The gel is preferred because it is easier to contain. The coating must be kept moist during the soak period. When ready to dry, absorb with cotton. Wipe area with a cotton "Q" tip that is wet with isopropyl alcohol. Do not allow area to dry itself.



2. Some of the conformal coating is absorbed into the Unresolve Plus S.G. The bulk of the coating will be softened and may be removed with a soft probe that will not damage the underlying parts. Clean area with cotton "Q" tip dampened with isopropyl alcohol.

NOTE

After cleaning, there shall be no evidence of flux residue or other contamination (corrosive materials).

(b) Reapply in accordance with conformal coating container instructions.

CAUTION

When heat is used to cure the film, do not exceed 250°F.

(2) Solid film lubricant.

(a) When it is necessary to strip the dry film lubricant, use a methyl-ethyl-ketone-soaked cloth to remove the old lubricant.

(b) Clean the surface with technical toluene or equivalent, prior to coating application.

(c) After solvent cleaning, do not touch the work area with bare hands.

(d) All 1 surfaces to be coated must be free of dirt, oil, grease, or other contamination at time of coating application.

(e) Spray the work area lightly with Solid Film Lubricant. Allow the first coat to air-dry about 2 minutes before applying a second coat. Coat an additional metal tab if necessary for thickness measurement.

(f) Adjacent areas must be masked to protect them from over-spray.

(g) The coating may be cured by one of two methods:

1. Air-dry for 6 hours before handling part. Full cure is achieved in 24 hours at room temperature.

2. Allow to dry for 10 minutes, then heat to 200° - 250° F. for 30 minutes. The part is then ready for functional use.

4-3. Monitoring Set.

a. General inspection procedures for the PITS are contained in TM 9-4935-484-14 and TM 9-6920-484-12.

b. Adjustment and alignment procedures for the MTS are contained in:

(1) General . TM 9-6920-484-12 and T14 9-4935-484-14.

(2) Specific. TM 9-4935-481-14-1.

c. Replacement and repair of MTS assemblies and subassemblies are as noted below.

NOTE

During disassembly, identify all wires before removal.

(1) Disassembly. Disassembly of the MTS is obvious by illustration (refer to TM 9-6920-480-24P-1), with the exception that the TARGET RANGE switch S2 must be rotated to position 1 prior to disassembly.

(2) Assembly. Assembly of the MTS is obvious by illustration, with the following exceptions:

(a) Power distribution panel .

1. Place power distribution panel in position on battery charger/regulator.

2. Install four retainer screws and torque them to 8-10 inch pounds.

3. Install plug P4, replace two retainer screws, and then torque the screws to 5-6 inch pounds.

(b) Voltmeter circuit card. Torque the retainer screws to 3-5 inch pounds.

(c) Voltmeter.

1. Place the meter gasket in position over the meter mounting point.

2. Install four mounting screws in the meter and place the meter on the mounting point.

3. Place lockwashers and flatwashers on the mounting screws.

4. Place the voltmeter circuit card with the mounting posts attached directly over the meter mounting point.

5. Start the mounting screws, then apply silicon rubber (RTV) to form a seal around the screws and torque them to 8-10 inch pounds.

(d) Jack J1 and J2.

1. Place gasket in position over jack mounting point.

2. Install insulation sleeving on the six wires.

3. Resolder the wires and heat shrink the tubing in place.

4. Position the jack for mounting.

5. Install four mounting screws, ground terminal lug, flatwashers, lockwashers, and nuts.

6. Apply silicon rubber (RTV) to form a seal around the screws and then torque the nuts to 8-10 inch pounds.

(e) Transformer T2. When installing the mounting screws, torque the nuts to 8-10 inch pounds.

(f) Transistor Q1. When installing Q1, apply thermal compound (MIS-6151) to both sides of the insulator plate before torquing the nuts to 8-10 inch pounds.

(g) Battery charger/voltage regulator subassembly. Torque all the screws to 8-10 inch pounds.

#### NOTE

If XA2 and XA3 are replaced during repair, the pins indicated in figure 4-1 must be removed from the connector bottoms to prevent unwanted electrical contact with the printed circuits on the A6 boards.

(h) BT1 and BT2. Torque mounting locknuts to 15-20 inch pounds and all other nuts to 5-6 inch pounds.

(i) Relay Assembly. Torque the mounting bolts to 8-10 inch pounds.

(j) Tracker indicator score meter. Use silicone rubber (RTV) to form a seal between meter and panel before installing the meter.

#### 4-4. Launch Effects Trainer.

a. General inspection procedures for the LET are contained in TM 9-6920-484-12.

b. Test procedures for the LET are contained in:

(1) General. TM 9-4935-484-14.

(2) Specific. TM 9-1425-484-24 and TM 9-4935-481-14-1.

c. Adjustment, alignment, replacement, and repair procedures for the LET are contained in TM 9-1425-484-24.

#### WARNING

To avoid injury to personnel, ensure that the cartridge chamber is empty.

#### NOTE

Offset Screwdriver (8035628) is needed in the disassembly and assembly of the LET. This tool is stored in the DMS-D lid.

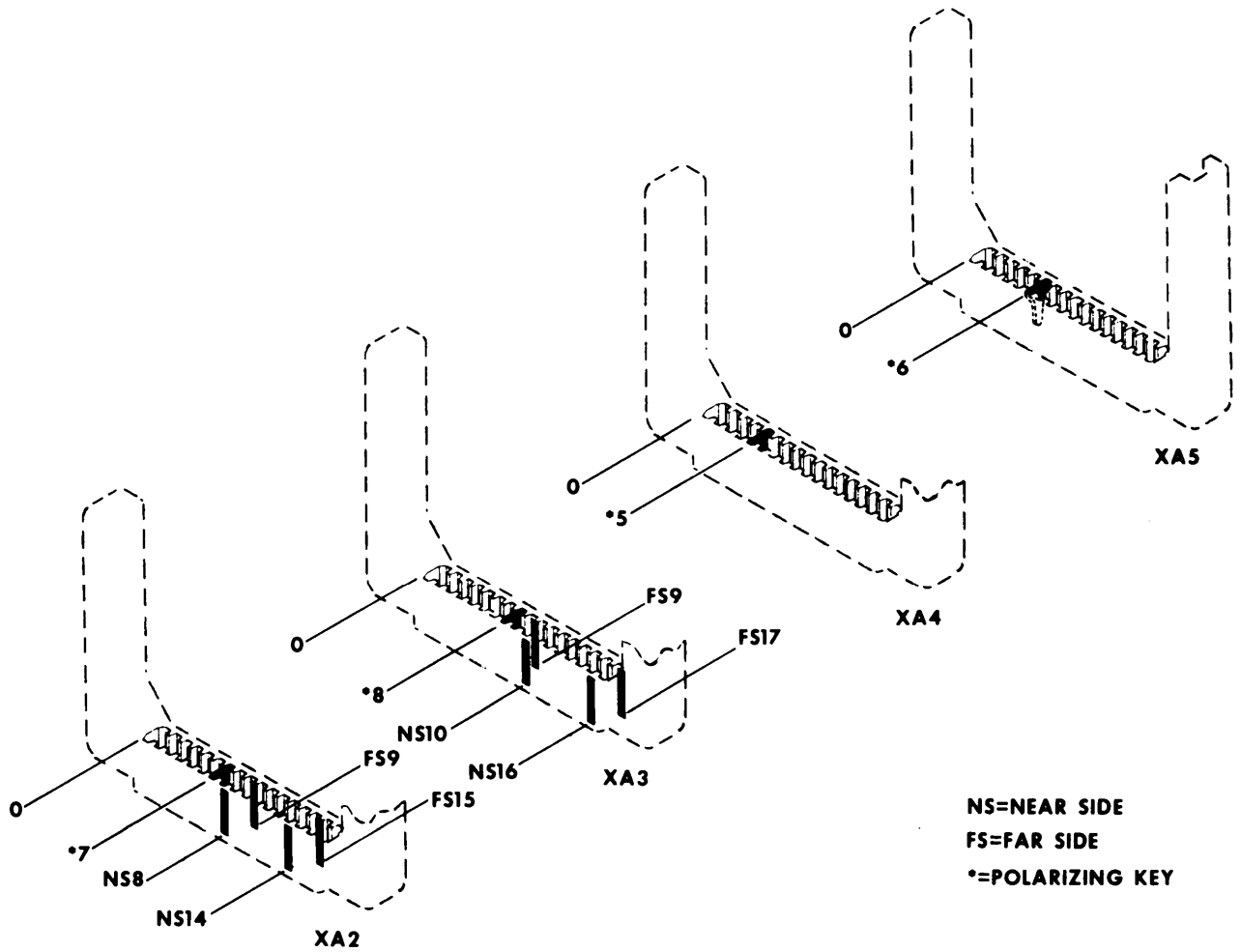

MS 161,564

Figure 4-1. Battery charger/regulator (10278445) - receptacle connector preparation.

4-5. IR Transmitter.

- a. Inspect the IR transmitter in accordance with the procedures contained in TM 9-6920-484-12.
- b. Test the IR transmitter in accordance with the procedures outlined in TM 9-6920-484-12 and TM 9-4935-481-14-1 or TM 9-6920-483-34-2.
- c. Adjust and align the IR transmitter in accordance with procedures outlined in TM 9-4935-481-14-1 or TM 9-6920-483-34-2.
- d. Replacement and repair of IR transmitter assemblies and subassemblies is obvious by illustration (refer to TM 9-6920-480-24P-1).

WARNING

The lamp bulb in the IR source is pressurized to about 215 psi. Safety goggles shall be worn and a protective shield for the body (such as a plexiglass panel) shall be used whenever disassembly beyond the filter retainers (i.e., within the housing) is necessary. If lamp bulb is to be handled, light gloves shall be worn. Failed bulbs shall be disposed of by enclosing them within a thick plastic bag before breaking with a tool with a flat surface such as a shovel. Disposal techniques similar to those for cathode ray tubes are recommended.



By Order of the Secretary of the Army:

BERNARD W. ROGERS  
*General, United States Army*  
*Chief of Staff*

Official:

PAUL T. SMITH  
*Major General, United States Army*  
*The Adjutant General*

Distribution:

To be distributed for stockage only to be issued upon request for Foreign Military Sales Cases.







